

Location and Extent Staff Report

DATE: OCTOBER 8, 2024
TO: DOUGLAS COUNTY PLANNING COMMISSION
FROM: CAROLYN WASHEE-FREELAND, AICP, SENIOR PLANNER *CWF*
JEANETTE BARE, AICP, PLANNING MANAGER *JB*
STEVEN E. KOSTER, AICP, ASSISTANT DIRECTOR OF PLANNING SERVICES *SK*
SUBJECT: **2259 HESS ROAD, PARKER WATER AND SANITATION DISTRICT, RIDGEGATE TANK PROJECT – LOCATION AND EXTENT**

PROJECT FILE: LE2024-025

OWNER:
PARKER WATER AND SANITATION DISTRICT
18100 E. WOODMAN DRIVE
PARKER, CO 80134

REPRESENTATIVE:
EMILIE ABBOTT
PARKER WATER AND SANITATION DISTRICT
18100 E. WOODMAN DRIVE
PARKER, CO 80134

PLANNING COMMISSION HEARING:

OCTOBER 21, 2024 @ 6:00 PM

I. EXECUTIVE SUMMARY

Parker Water and Sanitation District (“PWSD”) requests approval of a Location and Extent (L&E) to construct a new water storage tank, a communications tower, and other improvements on PWSD-owned property located north of Rueter-Hess Reservoir, (referenced as the “Ridgeway Tank Project” or “Project”). The property is located north of Hess Road, west of the PWSD Headquarters building.

The project site is in the central portion of Douglas County, located east of I-25 and north of the Rueter-Hess Reservoir. PWSD indicates that the project is necessary to expand the PWSD existing water systems capacity and serviceability, and operating network within the area.

II. REQUEST

A. Request

PWSD requests approval of a L&E for the construction of a new water tank, communications tower, and other improvements on PWSD-owned property located north of Rueter-Hess Reservoir.

B. Location

The project site is located on a 550-acre parcel owned by PWSD, located at Hess Road, north of the Rueter-Hess Reservoir. PWSD owns over 2,600 acres of land within the vicinity. The project site is located approximately 3 miles northeast of the I-25 and Castle Pines Parkway interchange. The project zoning, vicinity, and aerial maps are provided in the attachments to this staff report.

C. Project Description

The applicant is proposing to construct a water storage tank that will hold 3 million gallons of water, a communications tower (projected to be 130 to 180 feet in height), access road improvements, associated piping, and system controls equipment to expand the existing water system capacity and serviceability within the PWSD Water Pressure Zone 2 West area. PWSD has 3 separate water pressure zones within the water delivery system.

According to the applicant, the dimensions for the cylindrical shape water storage tank are 143 feet in diameter with a dome-shaped roof system, and the tank will be partially buried. The total height of the structure will be 54.55 feet, with 45 feet of the tank above ground. Additional components of the water tank design will include a 24-inch ductile iron water main, 3-inch fiber optic conduit, electrical conduits, Advanced Metering Infrastructure (AMI), and access road improvements.

The applicant is exploring the idea of painting an art mural around the sides and potentially the top of the water storage tank. The mural would depict natural themes such as western landscapes and/or local plants and animals. The color palette would be selected to blend in with the surrounding landscape. Should the applicant move forward with the art mural installation, the final artwork and color selection would be determined in conjunction with a chosen artist. If a mural is not selected, the applicant will paint the water storage tank in a solid natural color scheme, as shown on the Location and Extent plan set.

The proposed communication tower will range in height between 130 to 180 feet and will be mounted on a 40-foot x 40-foot concrete foundation. The tower will be located south of the new water storage tank, adjacent to the existing access road, and will include a small parking area for PWSD operation staff. A chain link fence is proposed for site enclosure, along with a single access gate on the north side.

The applicant has indicated that the final height of the tower will be based on the Federal Aviation Administration (FAA) final determination of the site. The communications tower will have all associated appurtenances, and an AMI antenna. The communications tower and the water storage tank will be connected into the PWSD overall communications system.

Construction activities are anticipated to be completed within a seven-month timeframe, starting in March 2025. According to the applicant, construction activities will take place between 7:00 a.m. to 7:00 p.m. Monday through Friday. The existing access drive from Hess Road will be the primary access to the project site during construction. The applicant is not able to predict exactly how much traffic will occur during construction, however, they indicate that there will be approximately two months of heavy truck traffic including 4 to 5 concrete trucks per day during the months of construction. The applicant foresees that once construction is complete, PWSD operations staff will have approximately 5 trips per week.

The applicant has indicated that noise may be a factor that will affect neighboring residents in the area. The nearest neighborhood to the site is located less than one mile northeast of the project area. The applicant states that noise from construction equipment will be short in duration and will be mitigated by implementing standard onsite maintenance procedures. Once construction is complete, the applicant predicts that noise will not impact the surrounding residential development.

III. CONTEXT

A. Background

The proposed water storage tank and associated improvements are part of the PWSD Ridgeway Tank project, as identified in the *PWSD 2020 Water and Wastewater Master Plan*. The applicant states that the Ridgeway Tank project will support water demand for the City of Lone Tree’s Ridgeway development and will provide additional water pressure support to the district’s overall water delivery system, as well as future developments located in the area. The applicant projects that the Ridgeway development will have a future population of 7,000 new residents. Residential household water supply demand is anticipated to be 3 million gallons per day.

The new communications tower will serve to expand the PWSD operating network. The applicant has indicated that proposed improvements are necessary to service the growing population and support the PWSD system expansion. PWSD provides water and wastewater services for 75,000 residents in the Town of Parker, areas of Lone Tree, Castle Pines, and unincorporated Douglas County, and is projected to nearly double its size by build-out in 2050 to 2060.

B. Adjacent Land Uses and Zoning

The project site is zoned Agricultural One (A-1). The following table reflects the zone districts and land uses surrounding the project area.

	Zoning	Land Use
North	City of Lone Tree - Ridgeway Investments Meridian International Business Center Planned Development (Stepping Stone)	Vacant; Single Family Residential

	Zoning	Land Use
South	Agricultural One (A-1) - Parcel owned by PWSD	Rueter-Hess Reservoir
East	Town of Parker - Parker Homestead Planned Development	Single Family Residential
West	Agricultural One	Vacant

IV. PHYSICAL SITE CHARACTERISTICS

A. Site Characteristics and Constraints

The overall topography of the PWSD 550-acre parcel is composed of rolling hills and natural vegetation with moderate to steep sloping hillsides transitioning westward into Badger Gulch. The new water storage tank and communications tower will be in the western portion of the parcel on undeveloped land, approximately 4,500 feet west of the PWSD main headquarters building, and 3,000 feet north of Hess Road. The project area is 1.37 acres, with 2.5 acres that will be disturbed during construction. The project site has slight contour elevations that range from 6,000 feet to 6,310 feet.

There is an existing pioneer gravesite within the general vicinity of the project area. The applicant has indicated that the overall design of the project will avoid impacts to the gravesite, which is of historic and archaeological interest. The applicant contracted with ERO Resources Corporation to complete a Cultural Resource Survey and Evaluative Testing report. ERO found that no mitigation was required to protect the gravesite, however, the gravesite area will be protected with temporary orange construction fencing during construction activities. The design of the proposed improvements will avoid the area of concern. The applicant has indicated that no additional protection for the gravesite will take place after construction has been completed.

B. Access

The Ridgeway Tank project will take access via a proposed driveway connection utilizing a curb-cut on the north side of Hess Road. Hess Road is a County-owned arterial roadway.

C. Drainage and Erosion

The applicant submitted a Phase III Drainage Report with this request, which concluded that the proposed project has been designed to conform to the Douglas County Storm Drainage Design and Technical Criteria Manual, and the MHFD Urban Storm Drainage Criteria Manual.

A Grading Erosion & Sediment Control (GESC) plan and report will be submitted to Douglas County Engineering Services for review and approval prior to permits being

issued for construction activities. Any additional requirements will be identified in referral comments to be provided by Public Works Engineering.

D. Floodplain

The project site is located within Zone X FEMA mapped floodplain. Zone X is classified as an area of minimal flood hazard.

V. PROVISION OF SERVICES

A. Fire Protection

The South Metro Fire Rescue Protection District (SMFRPD) provides fire and emergency medical services to the site. At the writing of this staff report, SMFRPD has not provided a referral comment.

B. Sheriff Services

The Douglas County Sheriff's Office (DCSO) provides emergency services to the site. At the writing of this staff report, the DCSO had not provided referral agency review comments.

C. Water and Sanitation

The new water storage tank and communications tower will be served by PWSD.

D. Utilities

The site falls within the jurisdiction of Xcel Energy for electric and gas service. At the writing of this staff report, Xcel Energy has not provided a referral comment.

E. Other Required Processes and Permits

The proposed project will require the following permits and approvals prior to commencement of construction:

- Public Works Engineering - Grading Erosion and Sediment Control (GESC) Plans and Permits and other applicable construction plans and permits
- Douglas County Building Division – building permits; and
- Federal Aviation Administration (FAA).

VI. PUBLIC NOTICE AND INPUT

Courtesy notices of an application in process were sent to abutting property owners. No responses were received from property owners at the time of the writing of this staff report.

Referral response requests were sent to referral agencies on September 30, 2024. Referral responses are due at the conclusion of the referral period on October 14, 2024, prior to the Planning Commission hearing. Agency responses received are included as an attachment to this staff report.

VII. STAFF ASSESSMENT

Staff has evaluated the application in accordance with Section 32 of the *Douglas County Zoning Resolution*. The applicant has indicated that the new water storage tank and communications tower, and other improvements will support water demand for Lone Tree’s Ridgeway development, provide additional water pressure support to the PWSD overall water delivery system, and expand its operating network to serve the growing population.

Should the Planning Commission approve the Location and Extent request, the applicant will be required to obtain any necessary permits for completion of the proposed water storage tank, communications tower, and other site improvements.

ATTACHMENTS	PAGE
Douglas County Land Use Application.....	7
Location and Extent Narrative and Community Impact Report.....	8
Zoning and Vicinity, Aerial Maps	19
Referral Agency Response Report.....	22
Referral Response Letters	25
Phase III Drainage Report.....	29
Location and Extent Plan Exhibits	57

LAND USE APPLICATION

Please complete, sign, and date this application. Return it with the required items listed on the Submittal Checklist to planningsubmittals@douglas.co.us. Submittals may also be mailed or submitted in person to Planning Services. *NOTE: The Planning Commission or the Board of County Commissioners should not be contacted regarding an open application.*

OFFICE USE ONLY

PROJECT TITLE: **13939 Ancestry Drive, PWSD Ridgeway Tank Location and Extent**

PROJECT NUMBER: **LE2024-025**

PROJECT TYPE: PWSD WATER TANK AND COMMUNICATIONS TOWER LOCATION AND EXTENTS

MARKETING NAME: PWSD RIDGEGATE TANK

PRESUBMITTAL REVIEW PROJECT NUMBER: PS2024-165

PROJECT SITE:

Address: 13939 ANCESTRY DRIVE

State Parcel Number(s): 2231-251-00-002

Subdivision/Block#/Lot# (if platted): Metes and Bounds: 0000051

PROPERTY OWNER(S):

Name(s): Parker Water & Sanitation District

Address: 13939 Ancestry Dr, Parker, CO 80134

Phone: 303-841-4627

Email: EAbbott@pwsd.org

AUTHORIZED REPRESENTATIVE: (Notarized Letter of Authorization is required from the property owner, unless the owner is acting as the representative)

Name: Rebecca Tejada, Director of Engineering | Emilie Abbott, Project Manager

Address: 13939 Ancestry Dr, Parker, CO 80134

Phone: 720-842-4272

Email: EAbbott@pwsd.org

To the best of my knowledge, the information contained on this application is true and correct. I have received the County's information sheet regarding the *Preble's Meadow Jumping Mouse*.

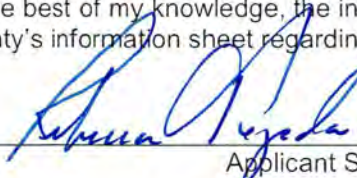
Applicant Signature

9/26/2024
Date

PWSD RIDGEGATE TANK

PARKER, COLORADO

LOCATION & EXTENT REPORT

SEPTEMBER 26, 2024

Prepared by:

Kimley»»Horn

For:



TABLE OF CONTENTS

1.0 INTRODUCTION.....	3
2.0 APPLICANT	4
3.0 PROJECT PURPOSE AND DESCRIPTION	4
3.1 IMPLEMENTATION SCHEDULE.....	6
3.2 ACCESS AND PROPOSED EASEMENTS.....	6
4.0 EXISTING CONDITIONS	7
5.0 IMPACTS AND MITIGATION.....	7
5.1 TRAFFIC IMPACTS AND MITIGATION.....	8
5.2 NOISE IMPACTS AND MITIGATION.....	8
5.3 DRAINAGE IMPACTS AND MITIGATION	9
6.0 REGULATORY AND PERMIT APPROVALS	9
6.1 COUNTY AND STATE REGULATORY REQUIREMENTS	9
6.2 FEDERAL AVIATION ADMINISTRATION	10
7.0 COMPLIANCE WITH DOUGLAS COUNTY COMPREHENSIVE MASTER PLAN	10

1.0 INTRODUCTION

This Location & Extent (L&E) Report has been prepared for the proposed Parker Water & Sanitation District (PWSD) Ridgeway Tank Project (“Project”) consisting of the construction of a three million-gallon (MG) water storage tank and associated piping and system controls to expand the existing water system’s capacity and serviceability within PWSD’s Zone 2 West as well as the construction of a communication tower to expand PWSD’s operating network, and access road improvements. Kimley Horn has prepared this application on behalf of PWSD to provide the information required for a L&E approval for the Project, in compliance with Section 32 of the *Douglas County Zoning Regulation*.

PWSD provides water and wastewater services for residents in the Town of Parker and areas of Lone Tree, Castle Pines, and unincorporated Douglas County. PWSD currently serves approximately 75,000 residents in its rapidly growing community and is projected to nearly double its size by build-out (2050/2060). The purpose of the water storage tank and associated communications tower and controls is to service the growing population and support PWSD system expansion. As outlined in the *PWSD 2020 Water and Wastewater Master Plan*, the Ridgeway tank will support demands for the anticipated Ridgeway Development as well as supporting pressures in Zone 2 West. The Ridgeway Development is expected to have an expected population of approximately 7,000 residents requiring a total of 3 MG per day of water supply to support household demands. The tank also supports serviceability in Zone 2 West by providing additional pressure to the system. PWSD system is separated into three pressure Zones on both the east and west sides of the system. **Figure 1** below depicts the pressure zone delineation within the PWSD system.

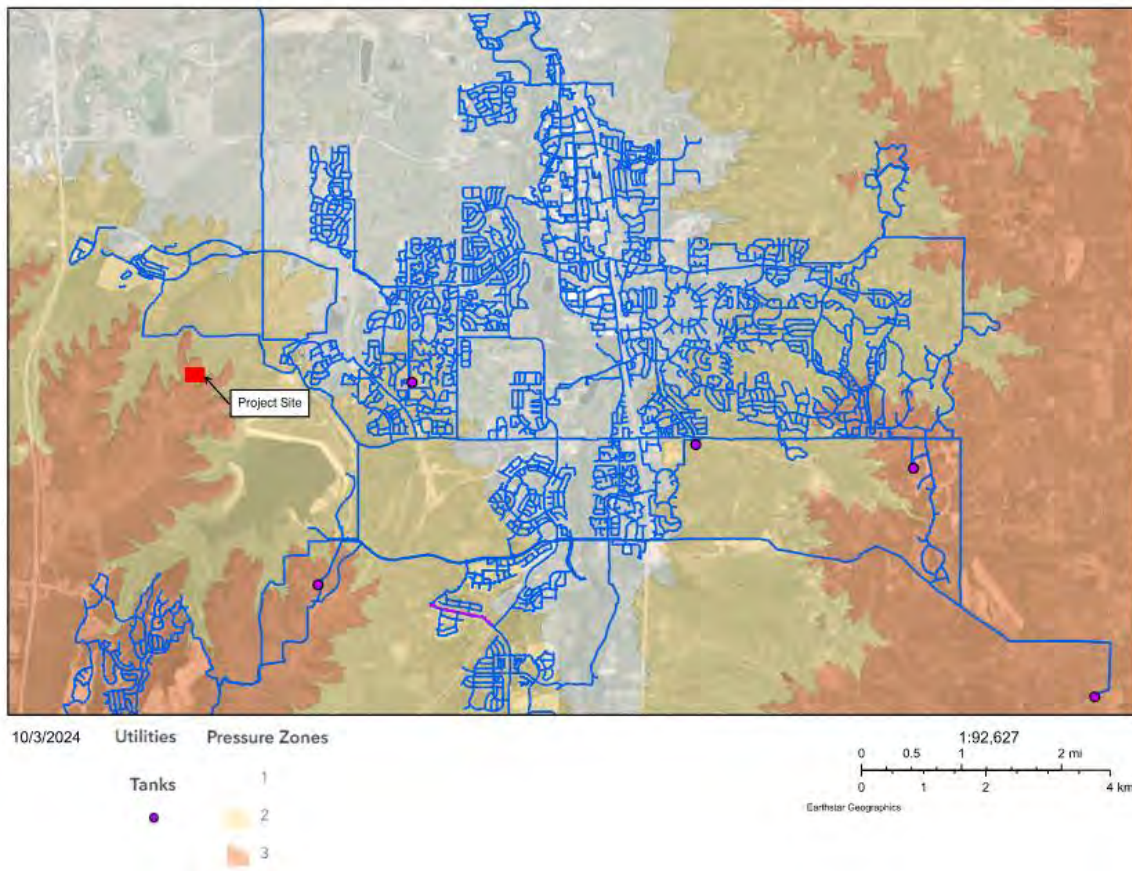

Figure 1: Water Pressure Zone 2 West

2.0 APPLICANT

The Applicant for this L&E approval pertains to:

Parker Water & Sanitation District
13939 Ancestry Drive
Parker, CO 80134
Emilie Abbott: (720) 842-4272
EAbbott@pwsd.org

The Applicant's representative is:

Kimley-Horn and Associates, Inc.
6200 South Syracuse Way, Suite 300
Greenwood Village, CO, 80111
Adam Monchak: (720) 943 9961
Adam.Monchak@kimley-horn.com

3.0 PROJECT PURPOSE AND DESCRIPTION

The Project is located in Douglas County, Colorado within Section 25, Township 6 South, Range 67 West of the 6th Principal Meridian. The Project site is within PWSD owned property (State Parcel No. 2231-251-00-002). The parcel has a total area of approximately 550 acres (AC), and the Project site is approximately 1.37 AC. The total disturbed area for all project components is approximately 2.5 AC. The average elevation of the project is 6,300 feet above mean sea level (MSL). The Project is bounded on the north by the Douglas County East/West Regional Trail, on the east by the Town of Parker, on the south by Hess Road, and on the west by undeveloped land owned by Freshfields, Inc. Preliminary design information pertaining to the Project is based on the *2020 Water and Wastewater Master Plan* ("PWSD Master Plan") for PWSD. As outlined in the PWSD Master Plan, the purpose of this Project is to provide the increased water storage required to service the growing Ridgeway Development as well as future developments located in Zone 2 West.

This Project consists of a partially buried 3-MG water storage tank, a 24-inch ductile iron water main, 3-inch fiber optic conduit, electrical conduits, access road improvements, Advanced Metering Infrastructure (AMI), and a communications tower. The site is anticipated to further expand with an additional water storage tank(s) as well as a booster pump station to service growth within PWSD's Zone 2 West; however, the timeline of future site expansion is currently unknown and will be based upon the buildout of Zone 2 West. Additional L&E applications will be submitted to Douglas County prior to construction of these future elements.

The water storage tank will be a cylindrical shape with a domed roof and is anticipated to have a diameter of 143 feet and a height of 54.55 feet; however, the tank will be partially buried to maintain proper hydraulic operations. A maximum height of 45 feet is anticipated to be exposed above grade. Final dimensions, including exposed height, will be finalized during the construction phase of this Project due to structural design of the tank being performed by the selected manufacturer. The maximum height of 45 listed within the L&E submittal documents is an estimate and will be confirmed in construction phase prior to beginning work on the structure itself.

PWSD is exploring the idea of painting an art mural around the sides and potentially the top of the tank. The mural would depict natural themes such as western landscapes and/or local plants and animals. The color palette would be selected to blend in with the surrounding landscape. If approved by the County and if PWSD elects to move forward with this art installation, the final artwork and color selection would be determined in conjunction with the chosen artist. If a mural is not selected, a solid natural color will be chosen to coat the tank. All color options are included in the exhibits associated with this application.

The water main will connect to the proposed tank to the existing system via an existing water main approximately 0.5 miles north of the site. The Project will be designed according to PWSD's *Engineering Department Standards and Specifications Manual* as well as per American Water Works Association (AWWA) standards. An AWWA D110, Type III water storage tank has been selected as the tank style for this Project by PWSD.

The electrical conduits will be aligned from the existing transformer north of the existing South Metro Fire communications building to the communications tower and the water storage tank to bring the required power to the site. The proposed fiber optic conduit will be run from the communication tower parallel with the water main to its point of connection with the existing water system. The scope of this Project includes installation of the fiber conduit only for future planning purposes and will be capped at both ends of the conduit until a future contractor is hired to install the fiber optic line itself.

The Advanced Metering Infrastructure (AMI) will aid PWSD in their water system operations management. The AMI consists of two elements the controls panel and the antenna. The control panel will be powered by a solar panel and placed within the fence around the communications tower. **Figure 2** below depicts an existing AMI control panel owned by PWSD. The antenna will be attached to the side of the communications tower and will add no additional height to the tower.



Figure 2: AMI Controls and Solar Panel

The communication tower is anticipated to be a maximum of 130 feet in height mounted on a 40-foot x 40-foot concrete foundation located south of the proposed tank, adjacent to the existing access road. The tower site will have access from the adjacent road and a parking area for PWSD operations staff. A chain link fence will surround the site and consist of a single access gate on the north side. As discussed in the Federal Aviation Administration (FAA) section of this report, the final height of the tower will be based on the FAA's final determination of the site. The final height of the tower will affect the foundation design as well as the placement of the electrical cabinet and an AMI unit. The foundation design described within this report is a conservative estimate of what the anticipated foundation design will be. The maximum height of 130 feet includes the foundation and all associated appurtenances, including the AMI antenna. With the

location of the communication tower at the site, the proposed tank would have the ability to be hard-wired into the communication system rather than needing additional communication equipment. **Figure 3**, shown below, illustrates the location of the Project site.



Figure 3: Vicinity Map

3.1 IMPLEMENTATION SCHEDULE

Table 1 below summarizes the proposed implementation schedule for the planning, design, permitting and construction of the Project.

Table 1: Implementation Schedule

TASK	BEGIN	END
Site Selection, Sizing Analysis, and Easement Acquisition	September 2023	December 2023
Design & Archaeological Survey	January 2024	May 2024
Preliminary Design	May 2024	August 2024
Douglas County Approval	September 2024	November 2024
Final Design and Bidding	September 2024	November 2024
CDPHE Review and Approval	September 2024	January 2025
Construction (PWSD Funded)	March 2025	October 2025

3.2 ACCESS AND PROPOSED EASEMENTS

Primary access to the site is anticipated to be via the existing access road off Hess Road south of the Project site. An existing double-swing gate is located at the entrance to the access drive and is currently and will continue to be locked and maintained by PWSD.

The property directly north of the Project site is owned by Public Service Company of Colorado and contains transmission and distribution power lines owned by Xcel Energy. A utility easement for the proposed waterline and fiber optic conduit is required to cross the property and connect to the existing waterline within the existing PWSD easement (REC NO. 2021115116). The Project team is coordinating with the landowner to complete the required easement documentation.

The Project site is entirely owned by PWSD; therefore, no additional easements are anticipated.

4.0 EXISTING CONDITIONS

The Project site is within PWSD owned property with a total area of approximately 550 AC, and the Project site is approximately 1.37 AC. The total disturbed area for all project components is 2.5 AC. Surrounding land use consists of rural residential and undeveloped properties. Existing vegetation is limited and consists of shortgrass with boulders, outcroppings, and crushed stone ranging in gradation. There are no existing site structures with exception of a potential existing Pioneer gravesite. The proposed tank and piping layout has been designed to avoid impacts to this structure of historic and archaeological interest. ERO Resources Corporation (ERO) performed a *Cultural Resource Survey and Evaluative Testing*, included as **Appendix A**, at the site to identify historical markers in the area and specify any mitigation requirements. ERO found that no mitigation is required; however, the potential gravesite area will be protected with a temporary orange construction fence during construction activities. The proposed structure and associated piping for this project and potential future expansions have been designed to avoid the area of concern (the southeast corner of the site). In an effort to not bring attention to the area no additional protection is anticipated after construction activities are completed.

Predominately, the property slopes to the north with various natural washes situated throughout. The site area is located on a plateau within the property consisting of slopes generally downward to the east reaching as much as ~27% and elevations ranging between 6,286 and 6,310-feet; however, a vast majority of the site is located at about 6,310 feet with slopes ranging between 0.15%-0.5% in an open area. This open area will allow for the construction of a new 3-MG tank and communication tower. The remaining open space will be dedicated for any future water storage tank(s) and/or pump station.

The Project is positioned adjacent to an existing access road that runs north and south from Hess Road to an existing fire communication facility. This existing access road shall be maintained to limit the construction needs for establishment of a new road and allow access to the site from the south of the property. The existing 24-inch water main, Ridgeway South Water Main, that will be utilized as the point of connection to the Zone 2 West water system for the proposed tank is located to the north of the site along the East/West Regional Trail.

5.0 IMPACTS AND MITIGATION

The construction of the Project has the potential to temporarily impact adjacent landowners and the public through changes to historical traffic, noise, and drainage patterns. Permanent structures include the proposed 3-MG water storage tank, associated yard piping and fencing, communication tower, and access drive.

Areas of temporary disturbance will be restored to match existing conditions and contours following completion of construction. There are no existing trees on the site. The anticipated landscaping will consist of drill seeding the permanently disturbed areas. Seeding areas are outlined in the exhibit associated with this L&E submittal.

There is no site lighting proposed on the site. There is anticipated lighting within the electrical cabinets only. However, the FAA is still reviewing site applications and may require a light on the communications tower and/or the water storage tank. These elements will be added if required by the FAA.

5.1 TRAFFIC IMPACTS AND MITIGATION

The existing gravel road stemming from Hess Road will be used to access the site during construction. The closest neighborhood to the site is located roughly 0.87 miles northeast of the Project. On days when concrete is placed, there will be numerous concrete trucks delivering concrete to the site throughout the day. There are two phases of construction that will have heavy concrete truck deliveries, when pouring the foundation and pouring the tank wall and dome panels. The foundation pour will occur over the course of a single day and have consistent truck traffic during the day to ensure a constant supply of concrete to achieve the required monolithic floor design. The foundation is approximately 300 cubic yards (CY) resulting in 33 concrete trucks to the site over the course of the day.

It is anticipated to have at most two months of heavy construction traffic to the site while the structural wall and dome panels are being poured. Total duration of this heavy traffic will be dependent on weather conditions. The number of trucks / trips on these heavy traffic days depends on factors such as selected contractor, concrete provider, and timing of the project. It is estimated that approximately 40 CY of concrete will be poured per day, resulting in 4-5 concrete trucks to the site per day. Overall, the maximum impact to traffic will be when the foundation is poured. The public should expect consistent traffic to and from the site during the described heavy traffic phases. Outside of these phases, daily trips for worker vehicles, PWSD and Kimley-Horn staff, and various equipment should be expected.

All construction traffic will enter the site through the primary access point along Hess Road, limiting disturbance to the nearby residential areas. If required, Kimley-Horn will work with PWSD and the contractor to help inform the homeowners in neighboring parcels in advance, so they are not surprised by increased traffic along Hess Road. Access to existing driveways cut from Hess Road will not be impacted by this Project. Additional traffic control measures and signage as deemed necessary will be utilized throughout the construction process. Construction traffic onsite might cause an increase level of dust, the contractor will mitigate dust with a water truck onsite to dampen the surrounding area as needed.

Once the water storage tank is constructed and put into service, PWSD operations staff will have at most, 5 trips per week in standard pick up trucks. No further impact to traffic is anticipated after construction of the Project has been completed.

5.2 NOISE IMPACTS AND MITIGATION

The Project will substantially comply with Douglas County's Noise Overlay District and Section 17A of the *Douglas County Zoning Resolution* throughout all phases of the construction schedule. Working hours for daily construction will be with the allowable 7:00am to 7:00pm, Monday through Friday. The contractor shall seek approval from Douglas County for alternate working hours outside of the schedule. These requests will be submitted and reviewed as required per the discretion of the contractor and approval by Douglas County.

Noise from supporting construction equipment will be short in duration as construction continues along the proposed sequenced water storage tank, associated piping and communication tower construction. The construction documents will include language to contractually require the future contractor on site to comply with Section 17A. The contractor will determine the means and methods to accomplish meeting the Noise Overlay District requirement. The contractor is permitted to mitigate levels of noise through the implementation of appropriately selected mufflers and white noise back up alarms. The contractor will mitigate noise levels by implementing standard onsite maintenance procedures.

Following substantial completion, additional noises related to the water storage tank and communication tower are not anticipated. The proposed piping will be buried and backfilled. The anticipated level of noise emitted from the water storage tank during typical operation will fall below the noise level standards for a residential zone district.

5.3 DRAINAGE IMPACTS AND MITIGATION

Site drainage is anticipated to maintain the existing drainage offsite, and the impact to the onsite and offsite drainage system is expected to be minimal. The site imperviousness will increase with the installation of the tank, communication tower, and associated foundations. Remaining drainage details are anticipated to be the same from pre-construction conditions to post-construction conditions. The Project will follow historic drainage patterns and is not anticipated to provide adverse impacts to downstream drainage infrastructure.

Proposed onsite grading will allow water to drain away from the proposed tank without interfering with the communication tower, future pump station, or proposed piping. To achieve the correct finished floor elevation, the north side of the proposed tank will have large slopes for final grade, similar to the existing site conditions. The slope will need to be properly stabilized to ensure that the slope remains in place during rain and snow/runoff events. The proposed tank has concrete paving, and the final grading will incorporate a similar approach with the same material or a grouted riprap slope stabilization.

Proposed piping will be installed via open cut trenching. All piping will be installed with a 60-inch minimum depth of cover, backfilled and compacted, and graded to pre-existing conditions. Disturbed areas that were not vegetated will be restored to match existing conditions.

Disturbed soils within the limits of disturbance have the potential to be subject to erosion and sediment runoff during storm events. A protective layer of topsoil and aggregate will be replaced to stabilize the site soil within the respective limits of disturbance. No existing detention facilities are located on the existing property. No streams or major drainageways are located within or adjacent to the Project. The Project lies outside the limits of an active floodplain or area with high flood hazard. No changes to the existing floodplain hydraulics or hydrologic patterns are anticipated.

An Erosion and Sediment Control Plan (ESCP) has been prepared for the Project in compliance with the Grading, Erosion, and Sediment Control (GESC) Permit. The required Phase III drainage report has been included within this submittal. The GESC and associated report will be submitted after the L&E application is processed. The ESCP will be submitted to Douglas County and contain project-specific control measures to minimize erosion and offsite sediment transport. All work will be conducted in accordance with the Douglas County GESC Permit and the Colorado General Permit COR400000.

6.0 REGULATORY AND PERMIT APPROVALS

6.1 COUNTY AND STATE REGULATORY REQUIREMENTS

A L&E submittal will be submitted to Douglas County. In pursuit of a GESC Permit, a ESCP will be submitted to Douglas County. Per the pre-application meeting with Douglas County, review by the Douglas County Building Department is not required.

Beyond Douglas County Planning and Development requirements, regulatory review with the Colorado Department of Public Health and Environment (CDPHE) is required. The CDPHE review will be associated with the design review for a public water facility. The tank design will be completed in compliance with the

CDPHE Water Quality Control Division Policy DW005 – *Design Criteria for Potable Water Systems*. The approach for CDPHE review will pertain to the initial submittal of the Project's 60% design for conditional approval, while final submittal to CDPHE will consist of final structural drawings/plans, which will occur upon completion by the contractor and tank supplier/designer. The initial submittal is anticipated to be completed with conditional approval at the end of 2024 / beginning of 2025 and the final CDPHE approval is anticipated to be completed in 2025, prior to construction.

6.2 FEDERAL AVIATION ADMINISTRATION

Submittal to the Federal Aviation Administration (FAA) is required due to the Project Site's proximity to the Centennial Airport, approximately 2 miles south of the airport. The Tank and Communication tower will be submitted separately, notifying the FAA of the project scope, location, timeline, and specifically overall structure height. Specifically, a FAA form 7460 will be submitted and 14 CFR Part 77 will be evaluated for any additional submittal requirements.

The notice for the communication tower was filed on August 8, 2024. Notice of preliminary findings were received on September 11, 2024, stating that a 2C certified survey was needed to confirm location and flight approach slope before a favorable determination can be written. The survey is currently underway, once submitted to the FAA it will be reviewed and the notice will be open for public comment for 37 days. Once the public comment period is closed, the FAA will determine the overall allowable height of the communications tower and any additional requirements, such as lighting, that are needed to construct the tower. The final height will also dictate the foundation requirements and in turn, the site layout regarding the electrical cabinet and AMI system within the fenced communications tower area. As previously discussed, the layout described in this application is a conservative estimate for the anticipated design.

The notice for the water storage tank is anticipated to be submitted after L&E approval is obtained and will follow a similar process to the communications tower application.

7.0 COMPLIANCE WITH DOUGLAS COUNTY COMPREHENSIVE MASTER PLAN

The Douglas County 2040 Comprehensive Master Plan (CMP) establishes goals, objectives, and policies to guide land use and growth throughout Douglas County. The Project substantially complies with the CMP and is consistent with the goals, objectives, and policies outlined in Sections 5 & 7, Community Resources and Water Supply. Project area is located within the High Plateau Subarea of the Nonurban Land Use area.

Goal 5-1: Ensure the provision of adequate community resources in an efficient and cost-effective manner.

- Objective 5-1A: Review existing and projected development to ensure that it does not overwhelm existing services.
 - Policy 5-1A.1: Consider buildout rates, projected demand, and capacity when evaluating proposed development.
- Objective 5-1B: Maintain a development pattern of contiguous and logical extensions of community resources and infrastructure.
 - Encourage new development to be contiguous to existing development and infrastructure.

The Project will expand capacity and increase water storage required to service the growing Ridgeway Development and future developments located in Zone 2 West per the PWSD Master Plan; thereby, supporting growth in the areas planned of planned development in northeast Douglas County.

Goal 5-5: Maintain high quality standards in planning for utility sites.

- Objective 5-5A: Minimize impacts to the surrounding area.
 - Policy 5-5A.1: Apply design standards to ensure compatibility.
 - Policy 5-5A.2: Recognize the technological, operational, maintenance, and safety constraints of these uses while balancing community desires to mitigate impacts to the natural and built environment.

The Project will include temporary impacts on the natural and built environment. The Project has been designed to accordance with applicable state and local regulatory design requirements for erosion and sediment control on site. Temporary erosion control measures will enhance stormwater quality within the project area by retaining sediment-laden runoff prior to discharging off-site.

Goal 7-1: Prolong the life of water resources.

- Objective 7-1C: Support Long-term water supply planning
 - Policy 7-1C.1: Encourage developments to obtain service from existing water providers.
 - Policy 7-1C.4: Support research and monitoring of water supplies within Douglas County
 - Policy 7-1C.6: Encourage proactive, collaborative efforts in developing a long-term water supply.





The Project will promote future development in the Zone 2 West region by providing a long term and consistent supply of potable water to service the growing demands in the northeast area of Douglas County. Sampling for water quality will be conducted on a weekly basis at the tank in addition to daily monitoring of water levels by PWSD; therefore, this data can be used to support research, monitoring, and planning for current and future water supplies in Douglas County.

PWSD 13939 ANCESTRY DR LOCATION AND EXTENT

LE2024-025
ZONING



LEGEND

-  Roads
-  Parcels - PARCELS
-  A1 - AGRICULTURAL ONE
-  CTY
-  PD - PLANNED DEVELOPMENT

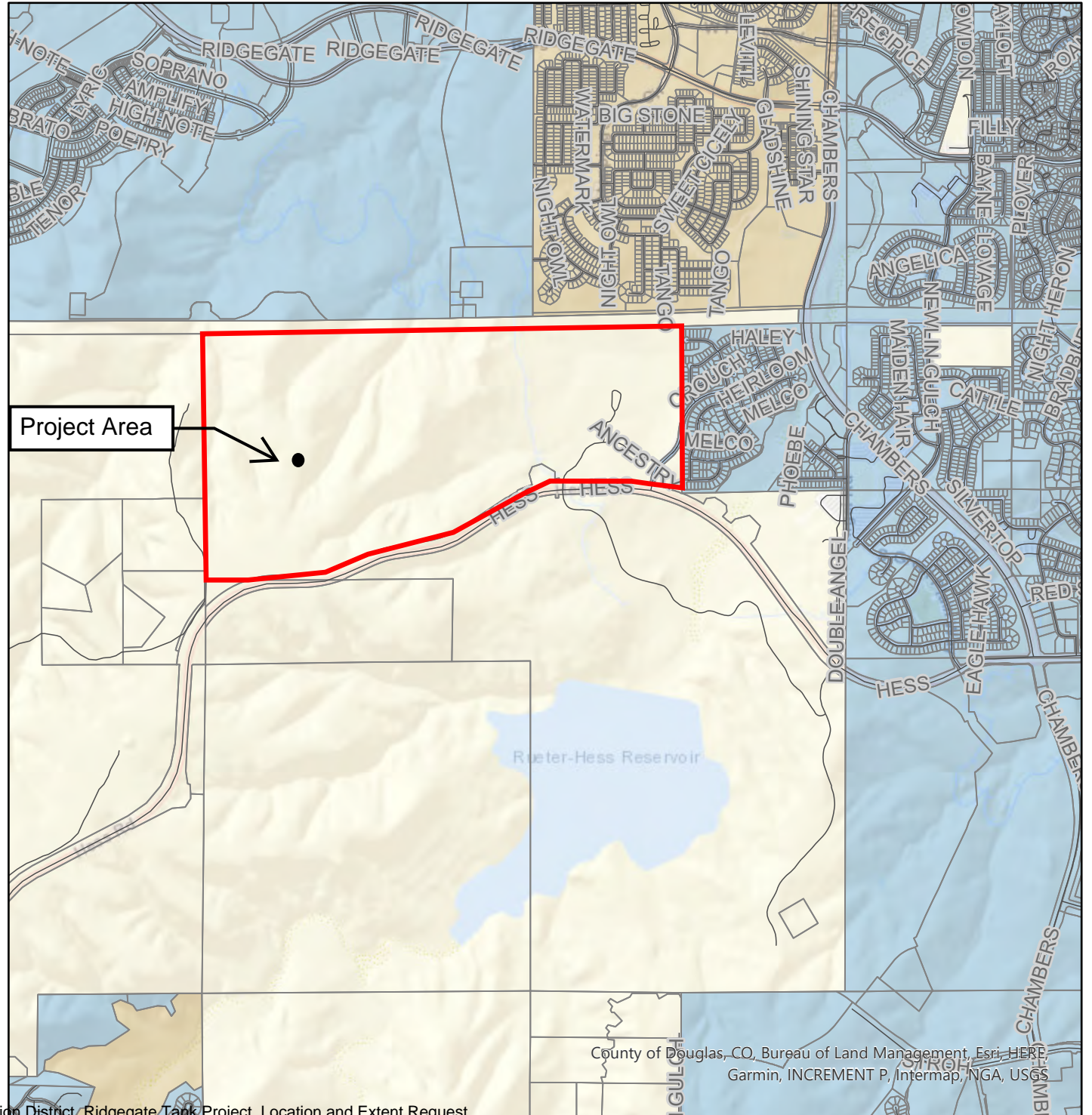

County of Douglas, CO, Bureau of Land Management, Esri, HERE,
Garmin, INCREMENT P, Intermap, NGA, USGS

PWSD 13939 ANCESTRY DR LOCATION AND EXTENT

LE2024-025

VICINITY MAP

LEGEND

 PROJECT SITE

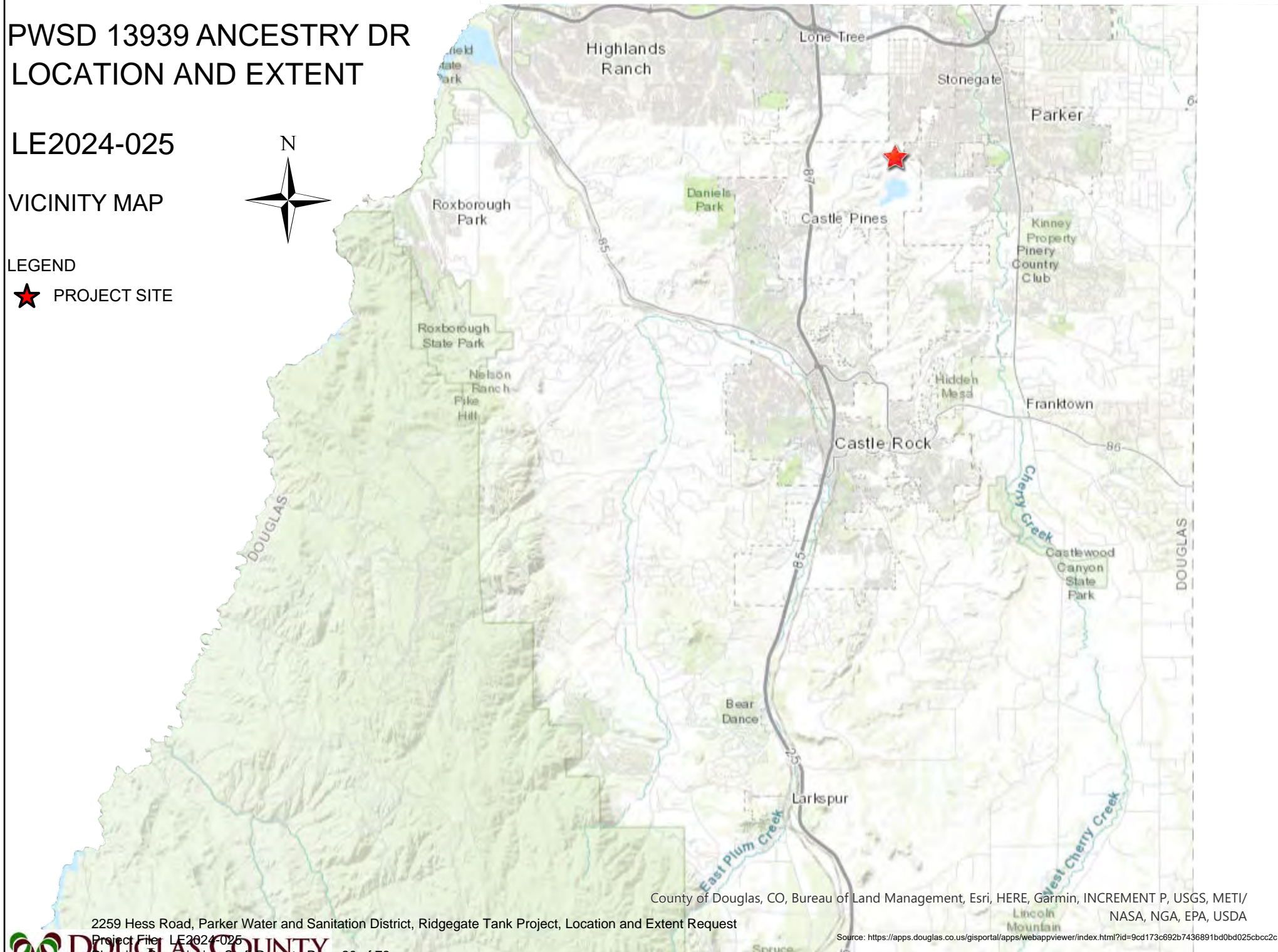

County of Douglas, CO, Bureau of Land Management, Esri, HERE, Garmin, INCREMENT P, USGS, METI/
NASA, NGA, EPA, USDA

2259 Hess Road, Parker Water and Sanitation District, Ridgeway Tank Project, Location and Extent Request

PWSD 13939
ANCESTRY DR
LOCATION AND EXTENT

LE2024-025
AERIAL



LEGEND

- Roads
- ▭ Parcels - PARCELS



Maxar

Initial Referral Agency Response Report

Project Name: Parker Water & Sanitation District, 2259 Hess Road, Ridgegate Water Tank Project – Location and Extent

Project File #: LE2024-025

Initial Referral: Date Sent: 09/30/2024 **Date Due:** 10/14/2024

Agency	Rec'd	Agency Response	Response Resolution
Addressing Analyst	Awaiting Referral Response		
Arapahoe County Public Airport Authority-Centennial	10/01/2024	Summary: The Arapahoe County Public Airport Authority has reviewed the documents and has no objection to the proposed development. We have the following comments to make on the project: Any objects on the site (including cranes used during construction) that penetrate a 100:1 slope from the nearest point of the nearest runway, penetrates the FAA Part 77 airspace surfaces, impede signals associated with navigational equipment or any other reason the FAA deems necessary will require the filing and approval of FAA Form 7460-1. Zachary Gabehart Planning Specialist - Noise & Environmental	Forwarded to applicant to address
Assessor	Awaiting Referral Response		
AT&T Long Distance - ROW	10/04/2024	Summary: There should be NO conflicts with the AT&T Long Lines, as we do not have facilities in that area. Ann Barnowski Clearwater Consulting Group Inc 120 9th Avenue South Suite 140 Nampa, ID 83651 Annb@cwc64.com	No action necessary
Black Hills Energy	Awaiting Referral Response		
Building Services	Awaiting Referral Response		
CenturyLink	10/02/2024	We have received your request for an Encroachment and have set up a Lumen project accordingly. Your project number is P863509 and it should be referenced in all emails sent n for review. Your project owner is Varina Hoopes and they can be reached by email at varina.hoopes@lumen.com with any questions that you may have regarding this project.	No action necessary

Project Name: Parker Water & Sanitation District, 2259 Hess Road, Ridgegate Water Tank Project – Location and Extent

Project File #: LE2024-025

Initial Referral: Date Sent: 09/30/2024 **Date Due:** 10/14/2024

		Kelley Franklin Faulk & Foster Project Coordinator Kelley.Franklin@lumen.com Kelley.Franklin@FaulkandFoster.com Direct 318.807.2619 Fax 318.807.2705 Faulk & Foster www.faulkandfoster.com	
Cherry Creek Basin Water Quality Authority	Awaiting Referral Response		
City of Castle Pines	Awaiting Referral Response		
City of Lone Tree	Awaiting Referral Response		
Comcast	Awaiting Referral Response		
CORE Electric Cooperative	Awaiting Referral Response		
Douglas County Health Department	Awaiting Referral Response		
Engineering Services	Awaiting Referral Response		
Office of Emergency Management	10/01/2024	OEM has no concerns with this project	No action necessary
Sheriff's Office	Awaiting Referral Response		
Sheriff's Office E911	Awaiting Referral Response		
South Metro Fire Rescue	Awaiting Referral Response		
Castle Park Ranch Property Owners Association	Awaiting Referral Response		
Oak Hills Owners Association	Awaiting Referral Response		
Surrey Ridge HOA	Awaiting Referral Response		
Rueter-Hess Recreation Authority	Awaiting Referral Response		
Mile High Flood District	10/07/2024	We appreciate the opportunity to review this proposal and have no comment, as this project does not include any major drainage features. We do not need to receive any future submittals on this project unless this changes. Katie Kerstiens, P.E., CFM Project Engineer (She, Her, Hers) MILE HIGH FLOOD DISTRICT 12575 W. Bayaud Ave. Lakewood, CO 80228	No action necessary

Project Name: Parker Water & Sanitation District, 2259 Hess Road, Ridgegate Water Tank Project – Location and Extent

Project File #: LE2024-025

Initial Referral: Date Sent: 09/30/2024 **Date Due:** 10/14/2024

		Office: 303-455-6277 Direct: 303-228-0148 www.udfcd.org	
Town of Parker Development Review	Awaiting Referral Response		
Town of Parker Public Works	10/07/2024	No Comment	No action necessary
Xcel Energy-Right of Way & Permits	Awaiting Referral Response		

Carolyn Freeland

From: annb cwc64.com <annb@cwc64.com>
Sent: Thursday, October 3, 2024 5:05 PM
To: Carolyn Freeland
Cc: Pam Choy (pc2914@att.com); duanew cwc64.com; jt cwc64.com
Subject: 13939 Ancestry Dr Parker, Colorado Douglas County eReferral #LE2024-025
Attachments: 13939 Ancestry Dr Parker, Colorado.jpg

Hi Carolyn,

This is in response to your eReferral with a utility map showing any buried AT&T Long Line Fiber Optics near 13939 Ancestry Dr Parker, Colorado. The Earth map shows the project area in red. Based on the address and/or map you provided, there should be NO conflicts with the AT&T Long Lines, as we do not have facilities in that area.

Please feel free to contact us with any questions or concerns

Ann Barnowski
Clearwater Consulting Group Inc
120 9th Avenue South
Suite 140
Nampa, ID 83651
Annb@cwc64.com

The attached google earth maps are intended to show approximate locations of the buried AT&T long line fiber optic cable. The maps are provided for informational purposes only. In no way should the maps be used for anything other than general guidelines as to where the fiber is or is not and any other use of these maps is strictly prohibited.

-----Original Message-----

From: cfreeland@douglas.co.us <cfreeland@douglas.co.us>
Sent: Monday, September 30, 2024 4:08 PM
To: annb cwc64.com <annb@cwc64.com>
Subject: Douglas County eReferral (LE2024-025) Is Ready For Review

There is an eReferral for your review. Please use the following link to log on to your account:
<https://apps.douglas.co.us/planning/projects/Login.aspx>

LE2024-025, Parker Water & Sanitation District Ridgeway Water Tank & Communications Tower Location and Extent Request

Parker Water & Sanitation District requests approval of a Location and Extent for the construction of a new water tank and communications tower, and other improvements on vacant property owned by Parker Water & Sanitation District, located at 13939 Ancestry Drive, SPN: 2231-251-00-002. The project site is located west of the Heirloom Pkwy and Hess Road intersection, north of the Rueter-Hess Reservoir.

This referral will close on October 14, 2024.

If you have any questions, please contact me.



13638 Ancestry Dr

Rueter-Hess Reservoir



REFERRAL RESPONSE REQUEST – LOCATION AND EXTENT

Date sent: **September 30, 2024**

Comments due by: **October 14, 2024**

Project Name: *Ridgeway Water Tank and Communications Tower, Parker Water & Sanitation District - Location and Extent*

Project File #: **LE2024-025**

Project Summary: Parker Water & Sanitation District requests approval of a Location and Extent for the construction of a new water tank and communications tower, and other improvements on vacant property owned by Parker Water & Sanitation District, located at 13939 Ancestry Drive, SPN: 2231-251-00-002. The project site is located west of the Heirloom Pkwy and Hess Road intersection, north of the Rueter-Hess Reservoir.

Information on the identified development proposal located in Douglas County is enclosed. Please review and comment in the space provided.

<input type="checkbox"/> No Comment	
<input type="checkbox"/> Please be advised of the following concerns:	
<hr style="border: 0; border-top: 1px solid black; margin-bottom: 5px;"/> <hr style="border: 0; border-top: 1px solid black; margin-top: 5px;"/>	
<input checked="" type="checkbox"/> See letter attached for detail.	
Agency: Arapahoe County Public Airport Authority	Phone #: 303-218-2919
Your Name: Zachary Gabehart <i>(please print)</i>	Your Signature: <i>Zachary Gabehart</i>
	Date: 10/01/24

A public hearing on this request will be held before the Douglas County Planning Commission on Monday, **October 21, 2024, at 6:00 pm; located at 100 Third Street, Castle Rock, CO 80104 in the Commissioner’s Hearing Room.**

Sincerely,

Carolyn Washee-Freeland
Carolyn Washee-Freeland, AICP
Senior Planner
303-660-7460
cfreeland@douglas.co.us
Enclosure



CENTENNIAL AIRPORT
ARAPAHOE COUNTY AIRPORT AUTHORITY

7565 South Peoria Street, Unit D9
Englewood, Colorado 80112
main: 303-790-0598 | fax: 303-790-2129
www.centennialairport.com

October 1st, 2024

Carolyn Washee-Freeland
Douglas County Community Development Department
100 Third Street
Castle Rock, CO 80104

Re: LE2024-025 – PWSD Water Tank and Communications Tower

Dear Ms. Washee-Freeland,

Thank you for the opportunity to review the location & extent plan. The Arapahoe County Public Airport Authority has reviewed the documents and has no objection to the proposed development. We have the following comments to make on the project:

- The proposed development lies approximately 4.06 miles from the nearest runway at Centennial Airport and just outside of the Airport Influence Area (AIA). This site location will be subjected to numerous aircraft over flights at low altitudes and their associated effects. These effects include, but are not limited to: noise, smoke, dust, fumes and vibrations
- Any objects on the site (including cranes used during construction) that penetrate a 100:1 slope from the nearest point of the nearest runway, penetrates the FAA Part 77 airspace surfaces, impede signals associated with navigational equipment or any other reason the FAA deems necessary will require the filing and approval of FAA Form 7460-1. This form may take 90 days or more for approval. Please visit <https://oeaaa.faa.gov> to utilize the notice criteria tool to confirm filing requirements and to file the FAA Form 7460-1. **Please note that this is a State and Federal regulatory requirement.** Runway endpoint data is available from the Airport for engineering calculations. In addition, please have crane operators advise Airport Operations (303-877-7307) prior to erecting any cranes.

Please feel free to call me if you have any questions.

Sincerely,

Zachary Gabehart
Planning Specialist - Noise & Environmental

PHASE III DRAINAGE REPORT



Ridgegate Tank Douglas County, Colorado

Prepared for:

**Emilie Abbott
Parker Water & Sanitation District
13939 Ancestry Drive
Parker, CO 80134**

Prepared by:

**Stephanie Maier, PE, CFM
Kimley-Horn and Associates, Inc.
6200 South Syracuse Way, Suite 300
Greenwood Village, Colorado 80111**

Kimley»Horn

Project #: 196231001

Prepared: October 2024

TABLE OF CONTENTS

CERTIFICATION STATEMENTS..... 3

SCOPE AND PURPOSE..... 4

I. GENERAL LOCATION AND DESCRIPTION 4

 A. LOCATION..... 4

 B. DESCRIPTION OF PROPERTY..... 4

II. DRAINAGE BASINS AND SUB-BASINS 4

 A. EXISTING MAJOR BASIN DESCRIPTION..... 4

 B. PROPOSED MAJOR BASIN DESCRIPTION..... 5

III. DRAINAGE DESIGN CRITERIA 5

 A. DEVELOPMENT CRITERIA REFERENCE..... 5

 B. HYDROLOGIC CRITERIA 5

 C. HYDRAULIC CRITERIA..... 6

 D. FLOODPLAIN CRITERIA 6

 E. ADAPTATION FROM CRITERIA..... 6

IV. DRAINAGE FACILITY DESIGN 6

 A. GENERAL CONCEPT 6

V. CONCLUSIONS 7

REFERENCES..... 7

Appendix A – General Maps / Relevant Excerpts
Appendix B – Hydrologic Calculations
Appendix C – Drainage Maps

CERTIFICATION STATEMENTS

This report and plan for the Phase III drainage design of the Ridgegate Tank was prepared by me (or under my direct supervision) in accordance with the provisions of *Douglas County Drainage Design and Technical Criteria* for the owners thereof. I understand that Douglas County does not and will not assume liability for drainage facilities designed by others.



Stephanie Maier, PE, CFM
Registered Professional Engineer
State of Colorado No. 62370

Parker Water & Sanitation District hereby certifies that the drainage facilities for Ridgegate Tank shall be constructed according to the design presented in this report. I understand that Douglas County does not and will not assume liability for the drainage facilities designed and/or certified by my engineer and that Douglas County reviews drainage plans pursuant to Colorado Revised Statutes, Title 30, Article 28; but cannot, on behalf of Ridgegate Tank, guarantee that final drainage design review will absolve Parker Water & Sanitation District and/or their successors and/or assigns of future liability for improper design. I further understand that approval of the final plat does not imply approval of my engineer's drainage design."

Emilie Abbott

PWSD Project Manager

[Handwritten Signature]

Authorized Signature

10/3/24

Date

SCOPE AND PURPOSE

The purpose of this Report is to outline the Phase III Drainage Design for the proposed Ridgegate Tank (the “Project”). This report presents the design details for the proposed drainage facilities to be constructed as part of the Project. The drainage design will conform to the current Douglas County Storm Drainage Design and Technical Criteria Manual.

I. GENERAL LOCATION AND DESCRIPTION

A. Location

The Ridgegate Tank Project is located approximately 3000-ft north of Hess Road and 4500-ft west of the Parker Water and Sanitation District building (the “Site”).

The Site is located in Section 25, Township 6 South, Range 67 West of the 6th Principal Meridian, Town of Parker, Douglas County, State of Colorado (see **Appendix A** for a Vicinity Map).

B. Description of Property

The Site is currently undeveloped land. The Project will consist of the construction of a new 3-MG water storage tank, transmission water line, and access drive. The total disturbance associated with the Project is approximately 0.8 acres. There are no existing irrigation canals or significant geologic features located on Site.

According to the Natural Resources Conservation Service (NRCS), the Site consists mostly of Hilly Gravelly Land and Fondis Clay Loam, 1-3% slopes, which are classified as Hydrologic Soil Group (HSG) D and C, respectively. HSG D was utilized for all runoff calculations for the Project. A Custom Soil Resource Report from the NRCS Web Soil Survey website for the Site is included as **Appendix A**.

According to the Federal Emergency Management Agency (FEMA) Flood Insurance Rate Map (FIRM) panels 08035C0063H (eff. 09/04/2020) and 08035C0064J (eff. 12/02/2021) for Douglas County and unincorporated areas, the Project is located in Zone X, which is classified as an area of minimal flood hazard. See **Appendix A** for the FEMA FIRM panels of the Project area.

II. DRAINAGE BASINS AND SUB-BASINS

A. Existing Major Basin Description

The Site is located within the Cherry Creek drainage basin. Existing storm runoff from the total 4.5-acres of the Site and contributing offsite area sheet flows toward one (1) of four (4) discharge locations as shown on the Existing Drainage Map provided in **Appendix C** and as summarized in **Table 1** below.

Table 1: Existing Drainage Basin Summary

	Area (ac)	Imp (%)	Q5 (cfs)	Q100 (cfs)
EX1	3.37	3%	0.64	9.77
EX2	0.51	2%	0.09	1.53
EX3	0.34	2%	0.06	0.97
EX4	0.24	7%	0.06	0.61
TOTAL	4.47	3%	0.84	12.88

Basin EX1 sheet flows north into an existing ditch toward Badger Gulch. Basins EX2, EX3, and EX4 sheet flow east toward Newlin Gulch. All runoff is eventually conveyed north to Cherry Creek via Badger Gulch or Newlin Gulch.

B. Proposed Major Basin Description

Proposed storm runoff will generally maintain existing drainage patterns and discharge to one (1) of four (4) discharge locations, as shown on the Proposed Drainage Map provided in **Appendix C** and as summarized in **Table 2** below.

Table 2: Proposed Drainage Basin Summary

	Area (ac)	Imp (%)	Q5 (cfs)	Q100 (cfs)
PR1A	1.42	3%	0.32	5.00
PR1B	1.95	26%	1.63	7.06
PR2	0.51	8%	0.17	1.64
PR3	0.34	2%	0.06	0.97
PR4	0.24	59%	0.42	1.06
TOTAL	4.47	17%	2.60	15.72

Basins PR1A and PR1B sheet flow north into an existing ditch toward Badger Gulch. Basins PR2, PR3, and PR4 sheet flow east toward Newlin Gulch. All runoff is eventually conveyed north to Cherry Creek via Badger Gulch or Newlin Gulch.

III. DRAINAGE DESIGN CRITERIA

A. Development Criteria Reference

This Drainage Report has been written in accordance with the *Douglas County Storm Drainage Design and Technical Criteria Manual*, and the *Mile High Flood District (MHFD) Urban Storm Drainage Criteria Manual (USDCM)*. There are no previous studies associated with the Site.

B. Hydrologic Criteria

Runoff Method

The Rational Method was used for all hydrologic calculations, as all delineated subbasins are less than 160 acres. Supporting hydrologic calculations for the existing and proposed analysis of the Site and contributing offsite area is included as **Appendix B**.

Rainfall and Storm Frequencies

According to Figure 6-1 of the Douglas County Storm Drainage Design and Technical Criteria Manual, the Site is located in Zone 1 (the area from the Douglas/Elbert County line west to the base of the foothills). The corresponding rainfall depths used for the Rational Method calculations were obtained from Table 6-2 of the Douglas County Storm Drainage Design and Technical Criteria Manual.

Per County criteria, hydrology is to be calculated for the 5-year and 100-year storm events, with the 5-year being the minor event, and the 100-year being the major event. The one-hour design rainfall depths are:

- 5-year: 1.43 inches
- 100-year: 2.60 inches

Runoff Coefficients

Composite runoff coefficients were calculated for each subbasin based on HSG D soils present on Site as identified in the NRCS soils report (**Appendix A**) and utilizing Section 2.7 (Table 6-3 and 6-5) from the MHFD USDCM.

Time of Concentration

The time of concentration for each subbasin was calculated utilizing the methods described in the Douglas County Storm Drainage Design and Technical Criteria Manual Section 6.3.2.

C. Hydraulic Criteria

Storm Sewer System

The Project does not include any proposed storm sewer infrastructure.

Onsite Detention

According to Chapter 13, Section 13.1 of the Douglas County Storm Drainage Design and Technical Criteria Manual, detention is required for all new development, redevelopment or expansion. However, as runoff is not significantly increasing with the proposed Site improvements, detention is not required.

Water Quality

As the Site is located within the Cherry Creek drainage basin, it is subject to both the Cherry Creek MS4 requirements and Douglas County MS4 requirements. However, since the total disturbance associated with the Project is less than 1-acre, and the Project is not part of a larger common plan of development, water quality treatment is not required.

D. Floodplain Criteria

As there is no portion of the Project is located within FEMA regulatory floodplain, there is no additional floodplain criteria to be met.

E. Adaptation from Criteria

There is no identified adaptation from criteria with the proposed Ridgegate Tank Project

IV. DRAINAGE FACILITY DESIGN

A. General Concept

The proposed drainage patterns will follow existing drainage patterns. All runoff is eventually conveyed north to Cherry Creek via Badger Gulch or Newlin Gulch.

Table 3: Existing/Proposed Drainage Comparison

Area (ac)		Imp (%)		Q5 (cfs)		Q100 (cfs)	
EX	PR	EX	PR	EX	PR	EX	PR
4.47	4.47	3%	17%	0.8	2.6	12.9	15.7

V. CONCLUSIONS

The Ridgegate Tank Project have been designed to conform to the Douglas County Storm Drainage Design and Technical Criteria Manual and the MHFD Urban Storm Drainage Criteria Manual. The Projects the requirements outlined in the Cherry Creek Reservoir Control Regulation No. 72 as the proposed drainage patterns will follow existing drainage patterns.

REFERENCES

Custom Soil Resource Report, Natural Resources Conservation Service, United States Department of Agriculture. Web Soil Survey. September 2024.

Flood Insurance Rate Map, Panel Number 08035C0063H, Federal Emergency Management Agency, Effective September 4, 2020.

Flood Insurance Rate Map, Panel Number 08035C0064J, Federal Emergency Management Agency, Effective December 2, 2021.

Storm Drainage and Technical Criteria Manual, Douglas County, July 2008.

Urban Storm Drainage Criteria Manual, Volumes 1-3, Mile High Flood District, latest revision.

APPENDIX A – GENERAL MAPS/RELEVANT EXCERPTS

Vicinity Map

Ridgegate Tank

Legend

 Project Location



National Flood Hazard Layer FIRMette



104°50'53"W 39°30'30"N

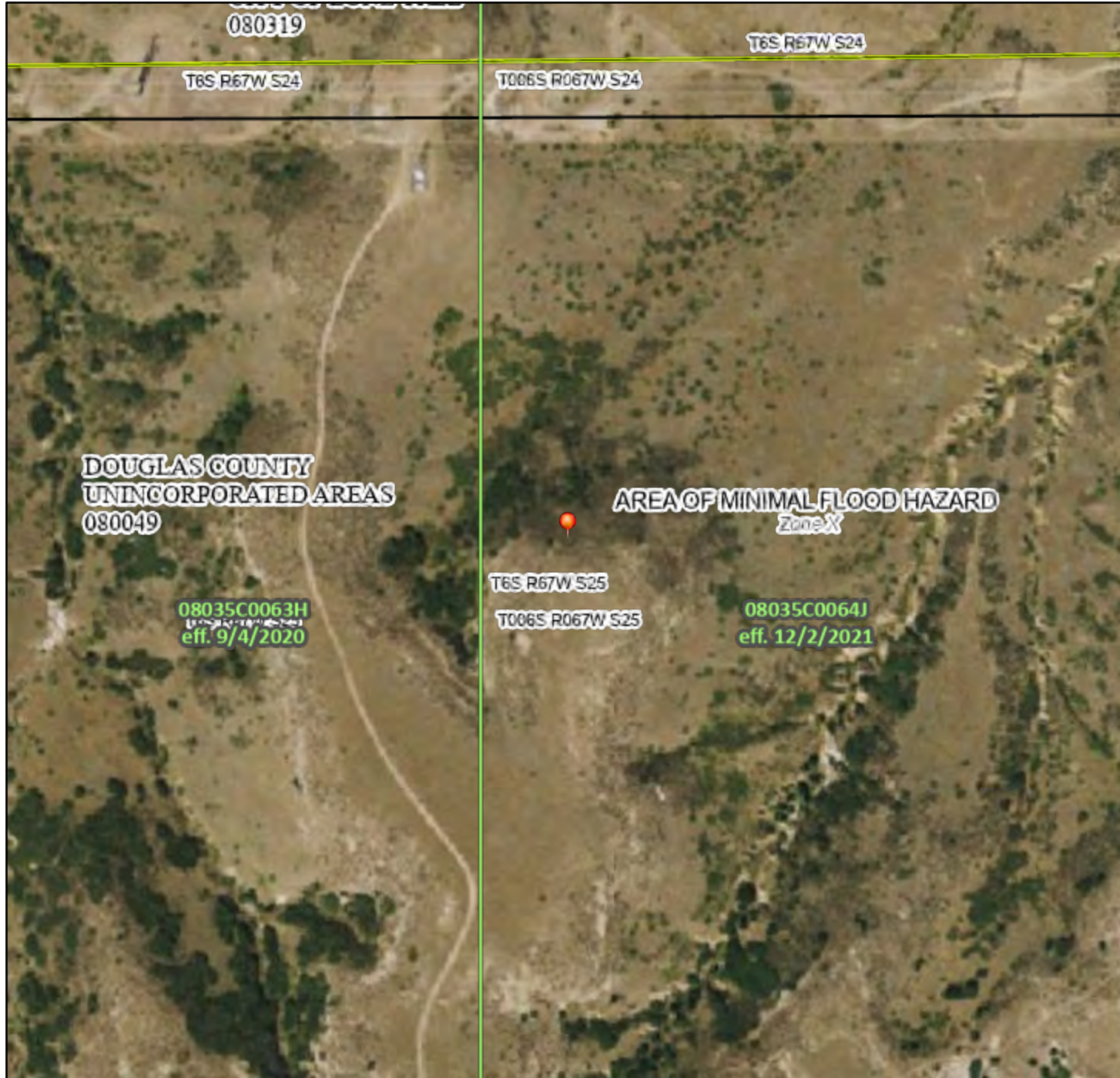

Legend

SEE FIS REPORT FOR DETAILED LEGEND AND INDEX MAP FOR FIRM PANEL LAYOUT

SPECIAL FLOOD HAZARD AREAS	Without Base Flood Elevation (BFE) Zone A, V, A99	With BFE or Depth Zone AE, AO, AH, VE, AR
	Regulatory Floodway	

OTHER AREAS OF FLOOD HAZARD	0.2% Annual Chance Flood Hazard, Areas of 1% annual chance flood with average depth less than one foot or with drainage areas of less than one square mile Zone X
	Future Conditions 1% Annual Chance Flood Hazard Zone X
	Area with Reduced Flood Risk due to Levee. See Notes. Zone X
	Area with Flood Risk due to Levee Zone D

OTHER AREAS	NO SCREEN Area of Minimal Flood Hazard Zone X
	Effective LOMRs
	Area of Undetermined Flood Hazard Zone D

GENERAL STRUCTURES	Channel, Culvert, or Storm Sewer
	Levee, Dike, or Floodwall

OTHER FEATURES	Cross Sections with 1% Annual Chance Water Surface Elevation
	20.2
	17.5
	Coastal Transect
	Base Flood Elevation Line (BFE)
	Limit of Study
	Jurisdiction Boundary
	Coastal Transect Baseline
	Profile Baseline
	Hydrographic Feature

MAP PANELS	Digital Data Available
	No Digital Data Available
	Unmapped

The pin displayed on the map is an approximate point selected by the user and does not represent an authoritative property location.

This map complies with FEMA's standards for the use of digital flood maps if it is not void as described below. The basemap shown complies with FEMA's basemap accuracy standards

The flood hazard information is derived directly from the authoritative NFHL web services provided by FEMA. This map was exported on **9/10/2024 at 4:00 PM** and does not reflect changes or amendments subsequent to this date and time. The NFHL and effective information may change or become superseded by new data over time.

This map image is void if the one or more of the following map elements do not appear: basemap imagery, flood zone labels, legend, scale bar, map creation date, community identifiers, FIRM panel number, and FIRM effective date. Map images for unmapped and unmodernized areas cannot be used for regulatory purposes.

2259 Hess Road, Parker Water and Sanitation District, Ridgegate Park Project, Location and Extent Request 104°50'16"W 39°30'21"N

0 250 500 1,000 1,500 2,000 Feet 1:6,000

Basemap Imagery Source: USGS National Map 2023







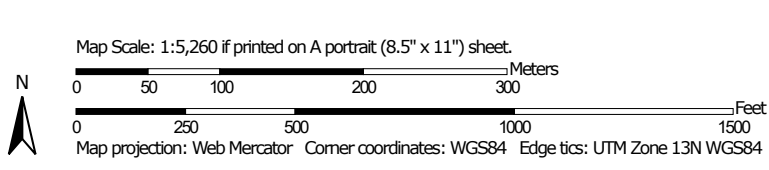

























Hydrologic Soil Group—Castle Rock Area, Colorado



Soil Map may not be valid at this scale.



MAP LEGEND

Area of Interest (AOI)		 C	C
	Area of Interest (AOI)	 C/D	C/D
Soils		 D	D
Soil Rating Polygons		 Not rated or not available	Not rated or not available
	A	Water Features	
	A/D		Streams and Canals
	B	Transportation	
	B/D		Rails
	C		Interstate Highways
	C/D		US Routes
	D		Major Roads
	Not rated or not available		Local Roads
Soil Rating Lines		Background	
	A		Aerial Photography
	A/D		
	B		
	B/D		
	C		
	C/D		
	D		
	Not rated or not available		
Soil Rating Points			
	A		
	A/D		
	B		
	B/D		

MAP INFORMATION

The soil surveys that comprise your AOI were mapped at 1:20,000.

Warning: Soil Map may not be valid at this scale.

Enlargement of maps beyond the scale of mapping can cause misunderstanding of the detail of mapping and accuracy of soil line placement. The maps do not show the small areas of contrasting soils that could have been shown at a more detailed scale.

Please rely on the bar scale on each map sheet for map measurements.

Source of Map: Natural Resources Conservation Service
 Web Soil Survey URL:
 Coordinate System: Web Mercator (EPSG:3857)

Maps from the Web Soil Survey are based on the Web Mercator projection, which preserves direction and shape but distorts distance and area. A projection that preserves area, such as the Albers equal-area conic projection, should be used if more accurate calculations of distance or area are required.

This product is generated from the USDA-NRCS certified data as of the version date(s) listed below.

Soil Survey Area: Castle Rock Area, Colorado
 Survey Area Data: Version 16, Aug 24, 2023

Soil map units are labeled (as space allows) for map scales 1:50,000 or larger.

Date(s) aerial images were photographed: Mar 1, 2023—Sep 1, 2023

The orthophoto or other base map on which the soil lines were compiled and digitized probably differs from the background imagery displayed on these maps. As a result, some minor shifting of map unit boundaries may be evident.

Hydrologic Soil Group

Map unit symbol	Map unit name	Rating	Acres in AOI	Percent of AOI
CoG	Coni rocky loam, 3 to 100 percent slopes	D	0.0	0.0%
FoB	Fondis clay loam, 1 to 3 percent slopes	C	5.9	4.4%
Fu	Fondis-Kutch association	C	32.4	24.1%
Hg	Hilly gravelly land	D	77.9	58.1%
NsE	Newlin-Satanta complex, 5 to 20 percent slopes	B	16.5	12.3%
RoE	Renohill sandy loam, reddish variant, 5 to 20 percent slopes	D	1.4	1.0%
Totals for Area of Interest			134.1	100.0%

Description

Hydrologic soil groups are based on estimates of runoff potential. Soils are assigned to one of four groups according to the rate of water infiltration when the soils are not protected by vegetation, are thoroughly wet, and receive precipitation from long-duration storms.

The soils in the United States are assigned to four groups (A, B, C, and D) and three dual classes (A/D, B/D, and C/D). The groups are defined as follows:

Group A. Soils having a high infiltration rate (low runoff potential) when thoroughly wet. These consist mainly of deep, well drained to excessively drained sands or gravelly sands. These soils have a high rate of water transmission.

Group B. Soils having a moderate infiltration rate when thoroughly wet. These consist chiefly of moderately deep or deep, moderately well drained or well drained soils that have moderately fine texture to moderately coarse texture. These soils have a moderate rate of water transmission.

Group C. Soils having a slow infiltration rate when thoroughly wet. These consist chiefly of soils having a layer that impedes the downward movement of water or soils of moderately fine texture or fine texture. These soils have a slow rate of water transmission.

Group D. Soils having a very slow infiltration rate (high runoff potential) when thoroughly wet. These consist chiefly of clays that have a high shrink-swell potential, soils that have a high water table, soils that have a claypan or clay layer at or near the surface, and soils that are shallow over nearly impervious material. These soils have a very slow rate of water transmission.

If a soil is assigned to a dual hydrologic group (A/D, B/D, or C/D), the first letter is for drained areas and the second is for undrained areas. Only the soils that in their natural condition are in group D are assigned to dual classes.

Rating Options

Aggregation Method: Dominant Condition

Component Percent Cutoff: None Specified

Tie-break Rule: Higher

APPENDIX B – HYDROLOGIC CALCULATIONS



**STANDARD FORM SF-1
RUNOFF COEFFICIENTS - IMPERVIOUS CALCULATION**

PROJECT NAME: Ridgeway Water Tank - EXISTING
 PROJECT NUMBER: 196231001
 CALCULATED BY: MCG
 CHECKED BY: SNM

DATE: 10/3/2024

SOIL: HSG D										
		Landscape	Roof	Paved/Gravel						
LAND USE:		AREA	AREA	AREA						
2-YEAR COEFF.		0.01	0.74	0.83						
5-YEAR COEFF.		0.05	0.77	0.86						
10-YEAR COEFF.		0.15	0.80	0.87						
100-YEAR COEFF.		0.49	0.85	0.89						
IMPERVIOUS %		2%	90%	100%						
DESIGN BASIN	DESIGN POINT	Landscape AREA (AC)	Roof AREA (AC)	Paved/Gravel AREA (AC)	TOTAL AREA (AC)	C(2)	C(5)	C(10)	C(100)	Imp %
On-Site Basins										
EX1	EX1	3.34	0.00	0.03	3.37	0.02	0.06	0.15	0.50	2.9%
EX2	EX2	0.51	0.00	0.00	0.51	0.01	0.05	0.15	0.49	2.0%
EX3	EX3	0.34	0.00	0.00	0.34	0.01	0.05	0.15	0.49	2.0%
EX4	EX4	0.23	0.00	0.01	0.24	0.06	0.10	0.19	0.51	7.4%
BASIN SUBTOTAL		4.42	0.00	0.05	4.47	0.02	0.06	0.15	0.50	3.0%
		99%	0%	1%	100%					



**STANDARD FORM SF-2
Time of Concentration**

PROJECT NAME: **Ridgegate Water Tank - EXISTING**
 PROJECT NUMBER: **196231001**
 CALCULATED BY: **MCG**
 CHECKED BY: **SNM**

DATE: #####

SUB-BASIN DATA			INITIAL TIME (T _i)			TRAVEL TIME (T _i)					T _c CHECK (URBANIZED BASINS)					FINAL T _c
DESIGN BASIN (1)	AREA Ac (2)	C5 (3)	LENGTH Ft (4)	SLOPE % (5)	T _i Min. (6)	LENGTH Ft. (7)	SLOPE % (8)	C _v (9)	VEL fps (11)	T _i Min. (12)	COMP. t _c (13)	TOTAL LENGTH (14)	TOTAL SLOPE (15)	TOTAL IMP. (16)	T _c Min. (17)	Min.
On-Site Basins																
EX1	3.373	0.059	100	2.8%	13.5	160	4.5%	7.0	1.5	1.8	15.3	260	3.8%	3%	27.9	15.3
EX2	0.509	0.051	100	3.1%	13.2	55	3.5%	7.0	1.3	0.7	13.9	155	3.2%	2%	27.2	13.9
EX3	0.345	0.051	100	2.9%	13.5	235	4.6%	7.0	1.5	2.6	16.1	335	4.1%	2%	28.6	16.1
EX4	0.243	0.096	100	1.1%	17.8	505	8.5%	7.0	2.0	4.1	22.0	605	7.3%	7%	28.5	22.0

$$t_i = \frac{0.395(1.1 - C_s)\sqrt{L_i}}{S_o^{0.33}}$$

$$t_i = \frac{L_i}{60K\sqrt{S_o}} = \frac{L_i}{60V_i}$$

$$t_i = (26 - 17i) + \frac{L_i}{60(14i + 9)\sqrt{S_o}}$$



**STANDARD FORM SF-3
STORM DRAINAGE DESIGN - RATIONAL METHOD 5 YEAR EVENT**

PROJECT NAME: Ridgeway Water Tank - EXISTING
 PROJECT NUMBER: 1.96E+08
 CALCULATED BY: MCG
 CHECKED BY: SNM

P₁ (1-Hour Rainfall) = **1.43**

DATE: 10/3/2024

STORM LINE (1)	DESIGN POINT (2)	DIRECT RUNOFF				TOTAL RUNOFF				STREET		PIPE			TRAVEL TIME			REMARKS (22)			
		DESIGN BASIN (3)	AREA (AC) (4)	RUNOFF COEFF (5)	t _c (min) (6)	C*A(ac) (7)	I (in/hr) (8)	Q (cfs) (9)	t _c (max) (10)	S(C*A) (ac) (11)	I (in/hr) (12)	Q (cfs) (13)	SLOPE (%) (14)	STREET FLOW(cfs) (15)	DESIGN FLOW(cfs) (16)	SLOPE (%) (17)	PIPE SIZE(in) (18)		LENGTH (ft) (19)	VELOCITY (20)	t _t (min) (21)
On-Site Basins																					
	EX1	EX1	3.37	0.06	15.3	0.20	3.21	0.64													
	EX2	EX2	0.51	0.05	13.9	0.03	3.36	0.09													
	EX3	EX3	0.34	0.05	16.1	0.02	3.14	0.06													
	EX4	EX4	0.24	0.10	22.0	0.02	2.68	0.06													



**STANDARD FORM SF-3
STORM DRAINAGE DESIGN - RATIONAL METHOD 100 YEAR EVENT**

PROJECT NAME: Ridggate Water Tank - EXISTING
 PROJECT NUMBER: 1.96E+08
 CALCULATED BY: MCG
 CHECKED BY: SNM

P₁ (1-Hour Rainfall) = **2.60**

DATE: 10/3/2024

STORM LINE (1)	DESIGN POINT (2)	DIRECT RUNOFF				TOTAL RUNOFF				STREET		PIPE			TRAVEL TIME			REMARKS (22)			
		DESIGN BASIN (3)	AREA (AC) (4)	RUNOFF COEFF (5)	t _c (min) (6)	C*A(ac) (7)	I (in/hr) (8)	Q (cfs) (9)	t _c (max) (10)	S(C*A) (ac) (11)	I (in/hr) (12)	Q (cfs) (13)	SLOPE (%) (14)	STREET FLOW(cfs) (15)	DESIGN FLOW(cfs) (16)	SLOPE (%) (17)	PIPE SIZE(in) (18)		LENGTH (ft) (19)	VELOCITY (20)	t (min) (21)
On-Site Basins																					
	EX1	EX1	3.37	0.50	15.3	1.67	5.84	9.77													
	EX2	EX2	0.51	0.49	13.9	0.25	6.12	1.53													
	EX3	EX3	0.34	0.49	16.1	0.17	5.71	0.97													
	EX4	EX4	0.24	0.51	22.0	0.12	4.87	0.61													



PROJECT NAME: Ridgegate Water Tank - EXISTING
 PROJECT NUMBER: 196231001
 CALCULATED BY: MCG
 CHECKED BY: SNM

DATE: 10/3/2024

RATIONAL CALCULATIONS SUMMARY

DESIGN POINT	TRIBUTARY BASINS	TRIBUTARY AREA (AC)	IMPERVIOUSNESS %	PEAK FLOWS (CFS)	
				Q5	Q100
On-Site Basins					
EX1	EX1	3.37	3%	0.64	9.77
EX2	EX2	0.51	2%	0.09	1.53
EX3	EX3	0.34	2%	0.06	0.97
EX4	EX4	0.24	7%	0.06	0.61
TOTAL		4.47	3%	0.84	12.88

**STANDARD FORM SF-1
RUNOFF COEFFICIENTS - IMPERVIOUS CALCULATION**

PROJECT NAME: Ridgeway Water Tank - PROPOSED
 PROJECT NUMBER: 196231001
 CALCULATED BY: MCG
 CHECKED BY: SNM

DATE: 10/3/2024

SOIL: HSG D

LAND USE:	Landscape AREA	Roof AREA	Paved/Gravel AREA
2-YEAR COEFF.	0.01	0.74	0.83
5-YEAR COEFF.	0.05	0.77	0.86
10-YEAR COEFF.	0.15	0.80	0.87
100-YEAR COEFF.	0.49	0.85	0.89
IMPERVIOUS %	2%	90%	100%

DESIGN BASIN	DESIGN POINT	Landscape AREA (AC)	Roof AREA (AC)	Paved/Gravel AREA (AC)	TOTAL AREA (AC)	C(2)	C(5)	C(10)	C(100)	Imp %
On-Site Basins										
PR1A	PR1A	1.41	0.00	0.01	1.42	0.02	0.06	0.15	0.50	2.8%
PR1B	PR1B	1.44	0.34	0.18	1.95	0.21	0.25	0.32	0.59	26.0%
PR2	PR2	0.48	0.03	0.00	0.51	0.06	0.10	0.19	0.52	7.7%
PR3	PR3	0.34	0.00	0.00	0.34	0.01	0.05	0.15	0.49	2.0%
PR4	PR4	0.09	0.10	0.05	0.24	0.49	0.52	0.57	0.73	59.5%
		3.76	0.47	0.24	4.47	0.13	0.17	0.25	0.55	16.5%
BASIN SUBTOTAL		84%	11%	5%	100%					



**STANDARD FORM SF-2
Time of Concentration**

PROJECT NAME: **Ridgegate Water Tank - PROPOSED**
 PROJECT NUMBER: **196231001**
 CALCULATED BY: **MCG**
 CHECKED BY: **SNM**

DATE: #####

SUB-BASIN DATA			INITIAL TIME (T _i)			TRAVEL TIME (T _i)					T _c CHECK (URBANIZED BASINS)					FINAL T _c
DESIGN BASIN (1)	AREA Ac (2)	C5 (3)	LENGTH Ft (4)	SLOPE % (5)	T _i Min. (6)	LENGTH Ft. (7)	SLOPE % (8)	C _v (9)	VEL fps (11)	T _i Min. (12)	COMP. t _c (13)	TOTAL LENGTH (14)	TOTAL SLOPE (15)	TOTAL IMP. (16)	T _c Min. (17)	Min.
On-Site Basins																
PR1A	1.421	0.058	100	8.6%	9.3	70	14.2%	7.0	2.6	0.4	9.8	170	10.9%	3%	26.4	9.8
PR1B	1.951	0.248	100	2.7%	11.2	340	9.4%	7.0	2.1	2.6	13.8	440	7.9%	26%	23.6	13.8
PR2	0.509	0.098	100	3.1%	12.6	55	3.5%	7.0	1.3	0.7	13.3	155	3.2%	8%	26.1	13.3
PR3	0.345	0.051	100	2.9%	13.5	235	4.6%	7.0	1.5	2.6	16.1	335	4.1%	2%	28.6	16.1
PR4	0.243	0.521	100	1.1%	10.3	505	8.5%	7.0	2.0	4.1	14.4	605	7.3%	59%	18.0	14.4
$t_i = \frac{0.395(1.1 - C_s)\sqrt{L_i}}{S_o^{0.33}}$ $t_i = \frac{L_i}{60K\sqrt{S_o}} = \frac{L_i}{60V_i}$ $t_i = (26 - 17i) + \frac{L_i}{60(14i + 9)\sqrt{S_o}}$																



**STANDARD FORM SF-3
STORM DRAINAGE DESIGN - RATIONAL METHOD 5 YEAR EVENT**

PROJECT NAME: Ridgegate Water Tank - PROPOSED
 PROJECT NUMBER: 1.96E+08
 CALCULATED BY: MCG
 CHECKED BY: SNM

P₁ (1-Hour Rainfall) = **1.43**

DATE: 10/3/2024

STORM LINE (1)	DESIGN POINT (2)	DIRECT RUNOFF				TOTAL RUNOFF				STREET		PIPE			TRAVEL TIME			REMARKS (22)			
		DESIGN BASIN (3)	AREA (AC) (4)	RUNOFF COEFF (5)	t _c (min) (6)	C*A(ac) (7)	I (in/hr) (8)	Q (cfs) (9)	t _c (max) (10)	S(C*A) (ac) (11)	I (in/hr) (12)	Q (cfs) (13)	SLOPE (%) (14)	STREET FLOW(cfs) (15)	DESIGN FLOW(cfs) (16)	SLOPE (%) (17)	PIPE SIZE (in) (18)		LENGTH (ft) (19)	VELOCITY (20)	t (min) (21)
On-Site Basins																					
	PR1A	PR1A	1.42	0.06	9.8	0.08	3.90	0.32													
	PR1B	PR1B	1.95	0.25	13.8	0.48	3.37	1.63													
	PR2	PR2	0.51	0.10	13.3	0.05	3.43	0.17													
	PR3	PR3	0.34	0.05	16.1	0.02	3.14	0.06													
	PR4	PR4	0.24	0.52	14.4	0.13	3.31	0.42													



**STANDARD FORM SF-3
STORM DRAINAGE DESIGN - RATIONAL METHOD 100 YEAR EVENT**

PROJECT NAME: Ridggate Water Tank - PROPOSED
 PROJECT NUMBER: 1.96E+08
 CALCULATED BY: MCG
 CHECKED BY: SNM

P₁ (1-Hour Rainfall) = **2.60**

DATE: 10/3/2024

STORM LINE (1)	DESIGN POINT (2)	DIRECT RUNOFF				TOTAL RUNOFF				STREET		PIPE			TRAVEL TIME			REMARKS (22)			
		DESIGN BASIN (3)	AREA (AC) (4)	RUNOFF COEFF (5)	t _c (min) (6)	C*A(ac) (7)	I (in/hr) (8)	Q (cfs) (9)	t _c (max) (10)	S(C*A) (ac) (11)	I (in/hr) (12)	Q (cfs) (13)	SLOPE (%) (14)	STREET FLOW(cfs) (15)	DESIGN FLOW(cfs) (16)	SLOPE (%) (17)	PIPE SIZE (in) (18)		LENGTH (ft) (19)	VELOCITY (20)	t (min) (21)
On-Site Basins																					
	PR1A	PR1A	1.42	0.50	9.8	0.70	7.10	5.00													
	PR1B	PR1B	1.95	0.59	13.8	1.15	6.13	7.06													
	PR2	PR2	0.51	0.52	13.3	0.26	6.24	1.64													
	PR3	PR3	0.34	0.49	16.1	0.17	5.71	0.97													
	PR4	PR4	0.24	0.73	14.4	0.18	6.02	1.06													



PROJECT NAME: Ridgeway Water Tank - PROPOSED
 PROJECT NUMBER: 196231001
 CALCULATED BY: MCG
 CHECKED BY: SNM

DATE: 10/3/2024

RATIONAL CALCULATIONS SUMMARY

DESIGN POINT	TRIBUTARY BASINS	TRIBUTARY AREA (AC)	IMPERVIOUSNESS %	PEAK FLOWS (CFS)	
				Q5	Q100
On-Site Basins					
PR1A	PR1A	1.42	3%	0.32	5.00
PR1B	PR1B	1.95	26%	1.63	7.06
PR2	PR2	0.51	8%	0.17	1.64
PR3	PR3	0.34	2%	0.06	0.97
PR4	PR4	0.24	59%	0.42	1.06
TOTAL		4.47	17%	2.60	15.72

APPENDIX C – DRAINAGE MAPS

Plotted By: Malar, Stephanie Sheet: Ridgegate Tank Layout GRADING October 03, 2024 09:27:26am K:\DEN_WATER\RESOURCES\196231001_PWS\DWG\DWG\Tank\CADD\Enhancements\DRN\DRN.dwg
 This document, together with the concepts and designs presented herein, is intended only for the specific purpose and client for which it was prepared. Reuse of and improper reliance on this document without written authorization and adaptation by Kimley-Horn and Associates, Inc. shall be without liability to Kimley-Horn and Associates, Inc.



LEGEND

- XXXX ----- EXISTING MAJOR CONTOUR
- XXXX ----- EXISTING MINOR CONTOUR
- | |
|-------|
| A |
| B C |

 EXISTING BASIN BUBBLE
 A = BASIN DESIGNATION
 B = AREA IN ACRES
 C = IMPERVIOUSNESS
- | |
|---|
| A |
|---|

 EXISTING DESIGN POINT DESIGNATION
- EXISTING BASIN BOUNDARY
- | |
|--|
| |
|--|

 EXISTING GRAVEL ROAD
- FLOW ARROW

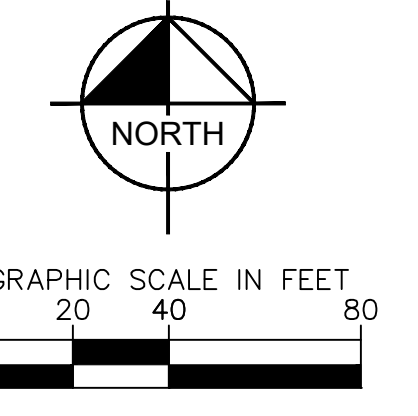

CAUTION: NOTICE TO CONTRACTOR

THE CONTRACTOR IS SPECIFICALLY CAUTIONED THAT THE LOCATION AND/OR ELEVATION OF EXISTING UTILITIES AS SHOWN ON THESE PLANS IS BASED ON RECORDS OF THE VARIOUS UTILITY COMPANIES AND, WHERE POSSIBLE, MEASUREMENTS TAKEN IN THE FIELD. THE INFORMATION IS NOT TO BE RELIED ON AS BEING EXACT OR COMPLETE. THE CONTRACTOR SHALL CALL UTILITY NOTIFICATION CENTER OF COLORADO (UNCC) AT 1-800-922-1987 OR DIAL 811 FOR UTILITY LOCATES 48 HOURS PRIOR TO ANY EXCAVATION WORK. IT SHALL BE THE RESPONSIBILITY OF THE CONTRACTOR TO RELOCATE ALL EXISTING UTILITIES WHICH CONFLICT WITH THE PROPOSED IMPROVEMENTS SHOWN ON THE PLANS.



<p>EXISTING CONDITIONS DRAINAGE MAP</p>	<p>RIDGEGATE TANK PREPARED FOR PARKER WATER & SANITATION DISTRICT COLORADO PARKER</p>																														
<p>Kimley-Horn © 2024 KIMLEY-HORN AND ASSOCIATES, INC. WWW.KIMLEY-HORN.COM PHONE: 303-228-2300 6200 SOUTH SYRACUSE, SUITE 300, GREENWOOD VILLAGE, CO 80111</p>	<p>PRELIMINARY FOR REVIEW ONLY NOT FOR CONSTRUCTION Kimley-Horn Kimley-Horn and Associates, Inc.</p>																														
<table border="1" style="width: 100%; border-collapse: collapse;"> <tr> <td style="width: 20%;">KHA PROJECT</td> <td>196231001</td> </tr> <tr> <td>DATE</td> <td>10/03/2024</td> </tr> <tr> <td>SCALE</td> <td>AS SHOWN</td> </tr> <tr> <td>DESIGNED BY</td> <td>MLC</td> </tr> <tr> <td>DRAWN BY</td> <td>ASD</td> </tr> <tr> <td>CHECKED BY</td> <td>ATM</td> </tr> </table>	KHA PROJECT	196231001	DATE	10/03/2024	SCALE	AS SHOWN	DESIGNED BY	MLC	DRAWN BY	ASD	CHECKED BY	ATM	<table border="1" style="width: 100%; border-collapse: collapse;"> <tr> <td style="width: 50%;">REVISIONS</td> <td style="width: 50%;">DATE</td> </tr> <tr> <td style="text-align: center;">No.</td> <td style="text-align: center;">BY</td> </tr> <tr> <td style="text-align: center;">1</td> <td style="text-align: center;">[Signature]</td> </tr> <tr> <td style="text-align: center;">2</td> <td style="text-align: center;">[Signature]</td> </tr> <tr> <td style="text-align: center;">3</td> <td style="text-align: center;">[Signature]</td> </tr> <tr> <td style="text-align: center;">4</td> <td style="text-align: center;">[Signature]</td> </tr> <tr> <td style="text-align: center;">5</td> <td style="text-align: center;">[Signature]</td> </tr> <tr> <td style="text-align: center;">6</td> <td style="text-align: center;">[Signature]</td> </tr> <tr> <td style="text-align: center;">7</td> <td style="text-align: center;">[Signature]</td> </tr> </table>	REVISIONS	DATE	No.	BY	1	[Signature]	2	[Signature]	3	[Signature]	4	[Signature]	5	[Signature]	6	[Signature]	7	[Signature]
KHA PROJECT	196231001																														
DATE	10/03/2024																														
SCALE	AS SHOWN																														
DESIGNED BY	MLC																														
DRAWN BY	ASD																														
CHECKED BY	ATM																														
REVISIONS	DATE																														
No.	BY																														
1	[Signature]																														
2	[Signature]																														
3	[Signature]																														
4	[Signature]																														
5	[Signature]																														
6	[Signature]																														
7	[Signature]																														
<p>SHEET NUMBER EX-1</p>																															

Project File: LE2024-025
 Planning Commission Staff Report Page 56 of 73
 2259 Hess Road, Parker Water and Sanitation District, Ridgeway Tank Project, Location and Extent Request
 Drawn by: Malar, Stephanie Sheet: Ridgeway Tank Layout: GRADING October 03, 2024 03:42:29pm K:\DEN_WATER\Resour\196231001_PWSID_Ridgeway Tank\CADD\Exhibits\Drainage\PR-DRN.dwg
 This document, together with the concepts and designs presented herein, is intended only for the specific purpose and client for which it was prepared. Reuse of and improper reliance on this document without written authorization and adaptation by Kimley-Horn and Associates, Inc. shall be without liability to Kimley-Horn and Associates, Inc.

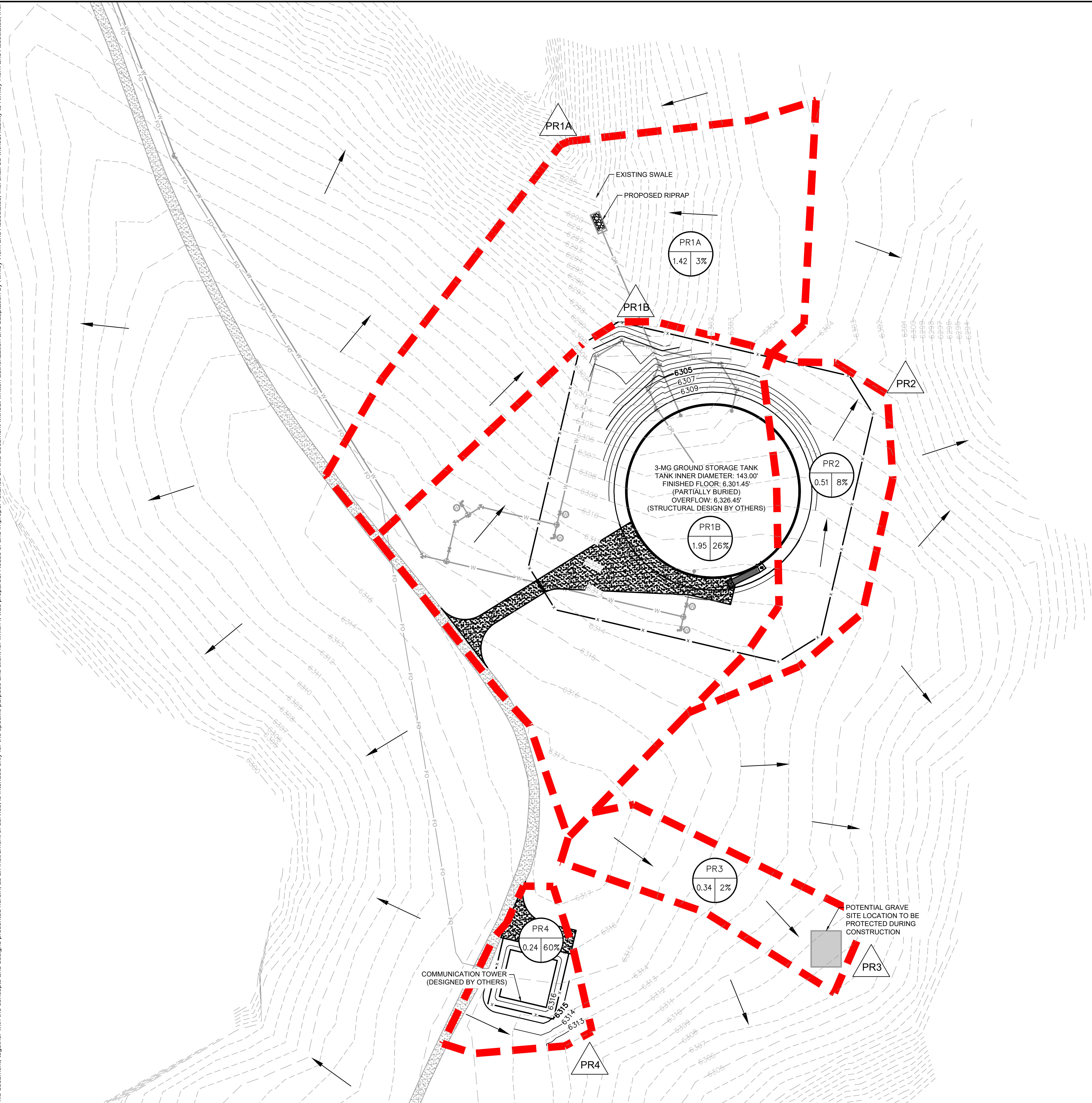

LEGEND

- XXXX ----- EXISTING MAJOR CONTOUR
- XXXX ----- EXISTING MINOR CONTOUR
- PROPOSED BASIN BUBBLE
 A = BASIN DESIGNATION
 B = AREA IN ACRES
 C = IMPERVIOUSNESS
- PROPOSED DESIGN POINT DESIGNATION
- PROPOSED BASIN BOUNDARY
- EXISTING GRAVEL ROAD
- FLOW ARROW
- PROPOSED MAJOR CONTOUR
- PROPOSED MINOR CONTOUR
- PROPOSED GRAVEL ROAD

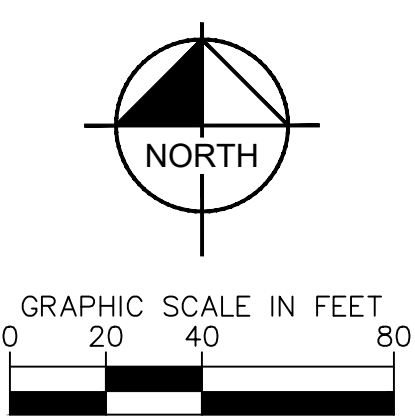

CAUTION: NOTICE TO CONTRACTOR
 THE CONTRACTOR IS SPECIFICALLY CAUTIONED THAT THE LOCATION AND/OR ELEVATION OF EXISTING UTILITIES AS SHOWN ON THESE PLANS IS BASED ON RECORDS OF THE VARIOUS UTILITY COMPANIES AND, WHERE POSSIBLE, MEASUREMENTS TAKEN IN THE FIELD. THE INFORMATION IS NOT TO BE RELIED ON AS BEING EXACT OR COMPLETE. THE CONTRACTOR SHALL CALL UTILITY NOTIFICATION CENTER OF COLORADO (UNCC) AT 1-800-822-1987 OR DIAL 811 FOR UTILITY LOCATES 48 HOURS PRIOR TO ANY EXCAVATION WORK. IT SHALL BE THE RESPONSIBILITY OF THE CONTRACTOR TO RELOCATE ALL EXISTING UTILITIES WHICH CONFLICT WITH THE PROPOSED IMPROVEMENTS SHOWN ON THE PLANS.



 © 2024 KIMLEY-HORN AND ASSOCIATES, INC. WWW.KIMLEY-HORN.COM PHONE: 303-228-2300 6200 SOUTH SYRACUSE, SUITE 300, GREENWOOD VILLAGE, CO 80111	
PRELIMINARY FOR REVIEW ONLY NOT FOR CONSTRUCTION Kimley-Horn and Associates, Inc.	
KHA PROJECT 196231001	DATE 10/03/2024
SCALE AS SHOWN	DESIGNED BY MLC
DRAWN BY ASD	CHECKED BY ATM
PROPOSED CONDITIONS DRAINAGE MAP	
RIDGEGATE TANK PREPARED FOR PARKER WATER & SANITATION DISTRICT	
COLORADO PARKER	
SHEET NUMBER PR-1	
REVISIONS	DATE

PARKER WATER & SANITATION DISTRICT RIDGEGATE TANK PROJECT LOCATION & EXTENT PLAN

DOUGLAS COUNTY, STATE OF COLORADO

SUBMITTAL: LE2024-025

Sheet List Table

Sheet Number	Sheet Title
1	COVER SHEET
2	OVERALL SITE PLAN
3	GRADING PLAN
4	TANK DETAILS
5	TANK DETAILS
6	FENCE DETAILS
7	COMMUNICATION TOWER DETAILS

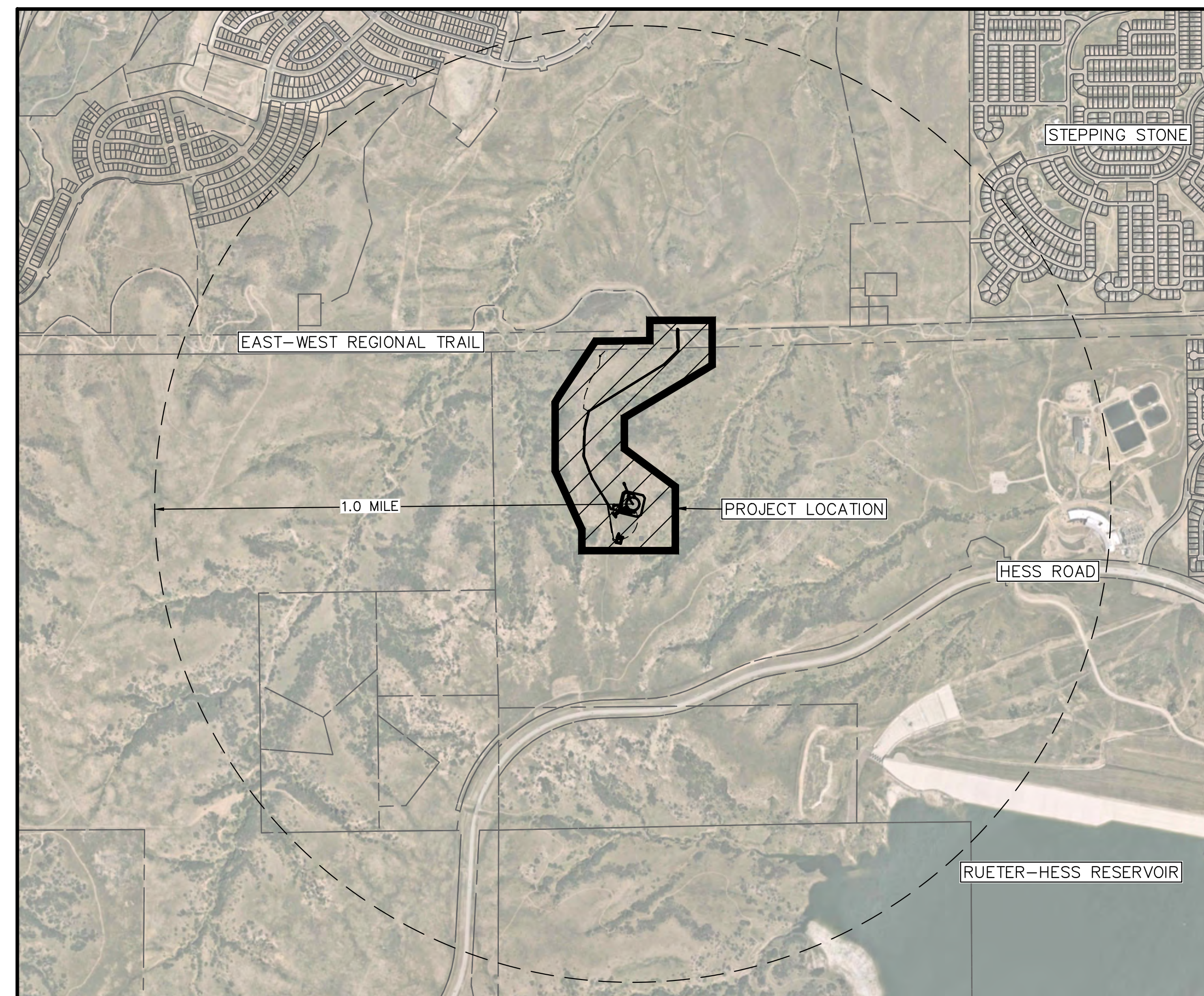

VICINITY MAP

1" = 1000'



BENCHMARK

NORTH AMERICAN VERTICAL DATUM OF 1988 (NAVD 88). VERTICAL CONTROL BASED UPON NGS DESIGNATION "GEOID 99". ALL BENCHMARK AND CONTROL INFORMATION CAN BE FOUND ON SHEET 2.

BASIS OF BEARINGS

ASSUMING THE TIE LINE BETWEEN THE POINT #251 AND #250, AS MONUMENTED BY A 3-1/4" BRASS DISK IN A ROCK AND A 3-1/4" ALUMINUM DISK TO BEAR NORTH OF 81°02'08" EAST, BEING A GRID BEARING OF THE COLORADO STATE PLANE COORDINATE SYSTEM, CENTRAL ZONE, NORTH AMERICAN DATUM 1983/2007, A DISTANCE OF 12,075.35 FEET WITH ALL BEARINGS CONTAINED HEREIN RELATIVE THERETO.

THIS DRAWING IS ON STATE PLANE GRID COORDINATES (CO STATE PLANE CENTRAL ZONE) TRUNCATED ACCORDING TO PARKER WATER & SANITATION DISTRICT'S ENGINEERING DEPARTMENT STANDARDS AND SPECIFICATIONS MANUAL (DATED JANUARY 2017):

FALSE NORTHING: 999,999.999996
 FALSE EASTING: 3,000,000.000316
 CENTRAL MERIDIAN: -105.50
 STANDARD PARALLEL 1: 38.45
 STANDARD PARALLEL 2: 39.75
 LATITUDE OF ORIGIN: 3.833333

SITE LOCATION

PROJECT SITE IS LOCATED WITHIN SECTION 24 AND 25, TOWNSHIP 6 SOUTH, RANGE 67 WEST OF THE 6TH P.M. PARKER, DOUGLAS COUNTY, COLORADO.

STATE PARCEL: 2231-251-00-002

PRESSURE ZONE: ZONE 2 WEST (PWS2)

AGENCIES

CIVIL ENGINEER: KIMLEY-HORN AND ASSOCIATES, INC.
 6200 SOUTH SYRACUSE WAY, SUITE 300
 GREENWOOD VILLAGE, CO, 80111
 ADAM MONCHAK: (720) 943-9961

OWNER: PARKER WATER & SANITATION DISTRICT
 13939 ANCESTRY DRIVE
 PARKER, CO 80134
 EMILIE ABBOTT: (720) 842-4272

SURVEYOR: BASELINE ENGINEERING, PLANNING, AND SURVEYING
 112 N. RUBEY DRIVE, #180
 GOLDEN, CO 80403
 JASON HAWLEY: (303) 202-5010

POTHOLING: RECONN UTILITY SERVICES
 1500 OCEAN AVE, SUITE A
 BOHEMIA, NY, 11716
 BEN PEREZ: (970) 420-8819

GEOTECHNICAL: KUMAR & ASSOCIATES, INC.
 2390 SOUTH LIPAN STREET
 DENVER, CO 80223
 JUSTIN CUPICH: (303) 742-9700



PRELIMINARY
 FOR REVIEW ONLY
 NOT FOR
 CONSTRUCTION

 Kimley-Horn and Associates, Inc.

KHA PROJECT	196231001
DATE	10/3/2024
SCALE	AS SHOWN
DESIGNED BY	MLC
DRAWN BY	ASD
CHECKED BY	ATM

COVER SHEET

RIDGEGATE TANK
 LOCATION & EXTENT PLAN
 PREPARED FOR
 DOUGLAS COUNTY
 COLORADO
 PARKER

SHEET NUMBER
1

This document, together with the concepts and designs presented herein, is an instrument of service, is intended only for the specific purpose and client for which it was prepared. Reuse of and improper reliance on this document without written authorization and adaptation by Kimley-Horn and Associates, Inc. shall be without liability to Kimley-Horn and Associates, Inc.

This document, together with the concepts and designs presented herein, as an instrument of service, is intended only for the specific purpose and client for which it was prepared. Reuse of and improper reliance on this document without written authorization and adaptation by Kimley-Horn and Associates, Inc. shall be without liability to Kimley-Horn and Associates, Inc.



LEGEND

- — — — — PROPERTY LINE
- — — — — WATER LINE
- — — — — DRAIN LINE
- — — — — FIBER CONDUIT
- — — — — ELECTRICAL CONDUIT
- — — — — FENCE
- — — — — EX UNDERGROUND ELECTRIC
- — — — — EX OVERHEAD ELECTRIC
- — — — — EX FENCE
- — — — — EX GRAVEL
- — — — — GRAVEL
- — — — — RIP RAP
- ▲ VALVE
- ▼ TEE
- 45° BEND
- 22.5° BEND
- 11.25° BEND
- WATER MANHOLE
- △ SURVEY CONTROL POINT
- SURVEY BENCHMARK
- ⊠ POTHOLES OBTAINED DURING DATA COLLECTION
- ⊞ SOIL BORINGS OBTAINED DURING DATA COLLECTION

SURVEY CONTROL DATA

POINT NO.	NORTHING	EASTING	ELEVATION	DESCRIPTION
BM-201	610288.91	185048.14	6299.10	6" CONCRETE PILLAR BRASS DISK
BM-250	613073.12	188026.88	6042.75	3.25" ALUMINUM DISK IN CONCRETE
BM-251	611191.50	177099.03	6124.41	3.25" BRASS DISK IN ROCK
CP-1	606326.97	184880.71	6357.89	BEG ALC
CP-2	608390.80	194816.99	6396.82	BEG 60D
CP-3	608240.27	185107.49	6314.99	BEG ALC #5 REBAR
CP-4	608310.58	185121.01	6315.55	BEG 60D
CP-6	610153.85	185039.38	6298.10	BEG ALC #5

NOTE: BM-250 & BM-251 ARE LOCAL NGS MONUMENTS LOCATED OUTSIDE OF THE SHOWN AREA.

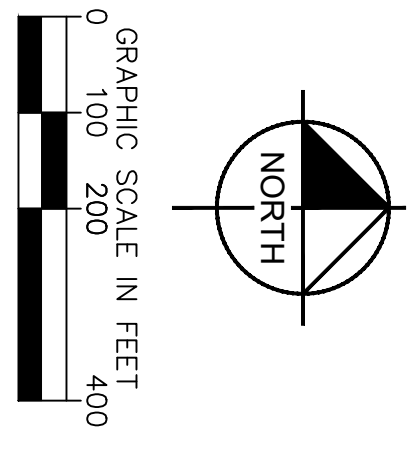

<p>RIDGEGATE TANK LOCATION & EXTENT PLAN PREPARED FOR DOUGLAS COUNTY</p> <p>PARKER COLORADO</p>	<p>OVERALL SITE PLAN</p>	<p>KHA PROJECT 196231001</p> <p>DATE 10/3/2024</p> <p>SCALE AS SHOWN</p> <p>DESIGNED BY MLC</p> <p>DRAWN BY ASD</p> <p>CHECKED BY ATM</p>	<p>PRELIMINARY FOR REVIEW ONLY NOT FOR CONSTRUCTION</p>	<p>Kimley-Horn</p> <p style="font-size: x-small;">© 2024 KIMLEY-HORN AND ASSOCIATES, INC. WWW.KIMLEY-HORN.COM PHONE: 303-228-2300 6200 SOUTH SYRACUSE, SUITE 300, GREENWOOD VILLAGE, CO 80111</p>	<p>ParkerWater & SANITATION DISTRICT</p>
<p>SHEET NUMBER 2</p>					

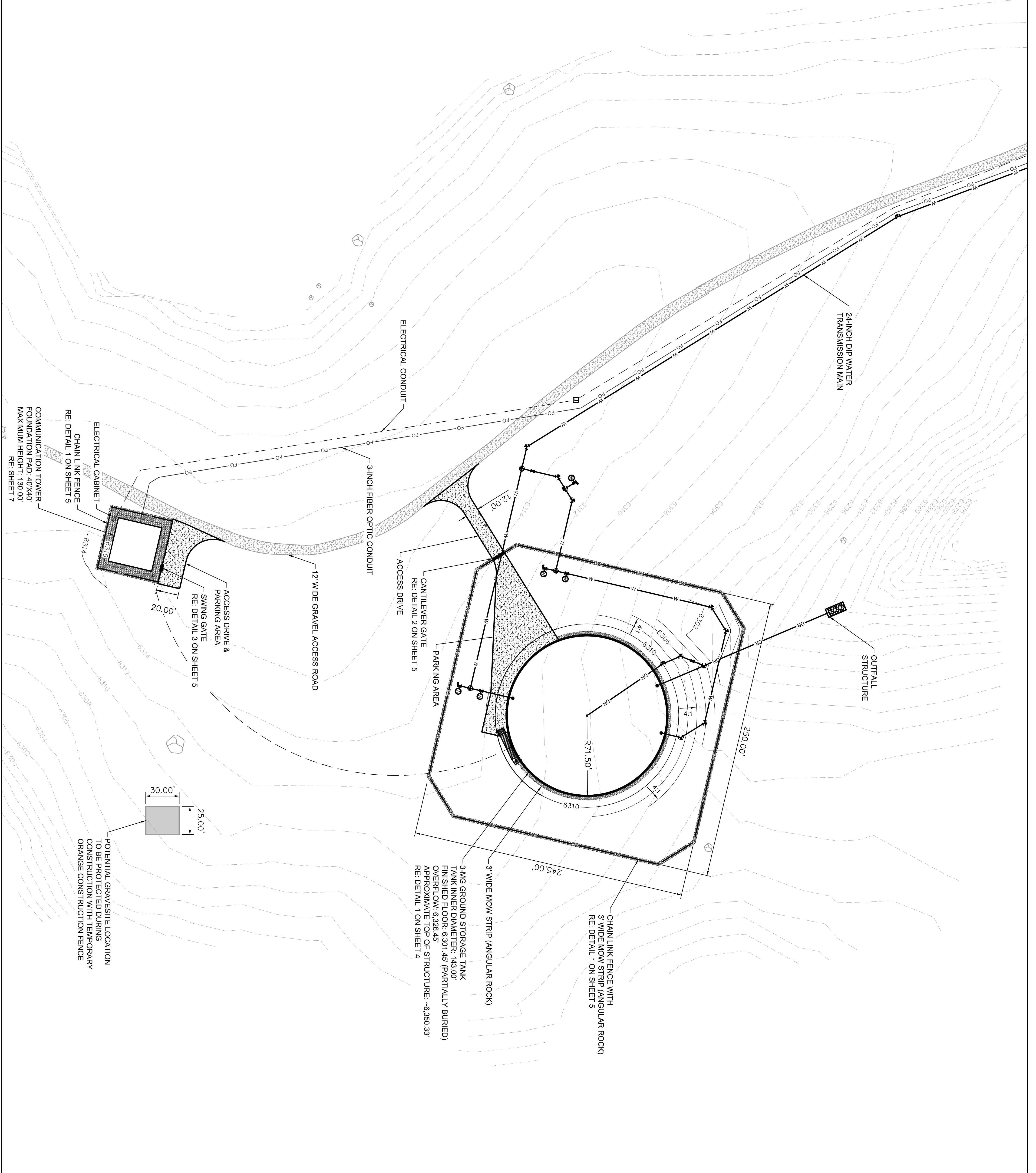

LEGEND

- PROPERTY LINE
- WATER LINE
- DRAIN LINE
- FIBER CONDUIT
- ELECTRICAL CONDUIT
- FENCE
- EX UNDERGROUND ELECTRIC
- EX OVERHEAD ELECTRIC
- EX FENCE
- EX GRAVEL
- GRAVEL
- RIP RAP
- VALVE
- TEE
- 45° BEND
- 22.5° BEND
- 11.25° BEND
- WATER MANHOLE
- SURVEY CONTROL POINT
- SURVEY BENCHMARK
- POTHOLES OBTAINED DURING DATA COLLECTION
- SOIL BORINGS OBTAINED DURING DATA COLLECTION

KEY MAP
1" = 600'

<p>RIDGEGATE TANK LOCATION & EXTENT PLAN PREPARED FOR DOUGLAS COUNTY</p> <p>PARKER COLORADO</p>	<p>GRADING PLAN</p>	<p>KHA PROJECT 196231001</p> <p>DATE 10/3/2024</p> <p>SCALE AS SHOWN</p> <p>DESIGNED BY MLC</p> <p>DRAWN BY ASD</p> <p>CHECKED BY ATM</p>	<p>Kimley»Horn</p> <p>© 2024 KIMLEY-HORN AND ASSOCIATES, INC. WWW.KIMLEY-HORN.COM PHONE: 303-228-2300 6200 SOUTH SYRACUSE, SUITE 300, GREENWOOD VILLAGE, CO 80111</p>	<p>ParkerWater & SANITATION DISTRICT</p>
-------------------------------------------------------------------------------------------------------------------------------	----------------------------	---------------------------------------------------------------------------------------------------------------------------------------------------	--------------------------------------------------------------------------------------------------------------------------------------------------------------------------------------	---------------------------------------------------------

Plotted By: DeFries, Austin, Sheet Set: PWSD L&E Layout: DETAILS | October 03, 2024, 04:24:54pm | K:\DEN WaterResources\196231001_PWSD Ridgigate Tank\CADD\PlanSheet\AEC-TANK DETL_L&E.dwg
 This document, together with the concepts and designs presented herein, is an instrument of service, is intended only for the specific purpose and client for which it was prepared. Reuse of and improper reliance on this document without written authorization and adaptation by Kimley-Horn and Associates, Inc. shall be without liability to Kimley-Horn and Associates, Inc.

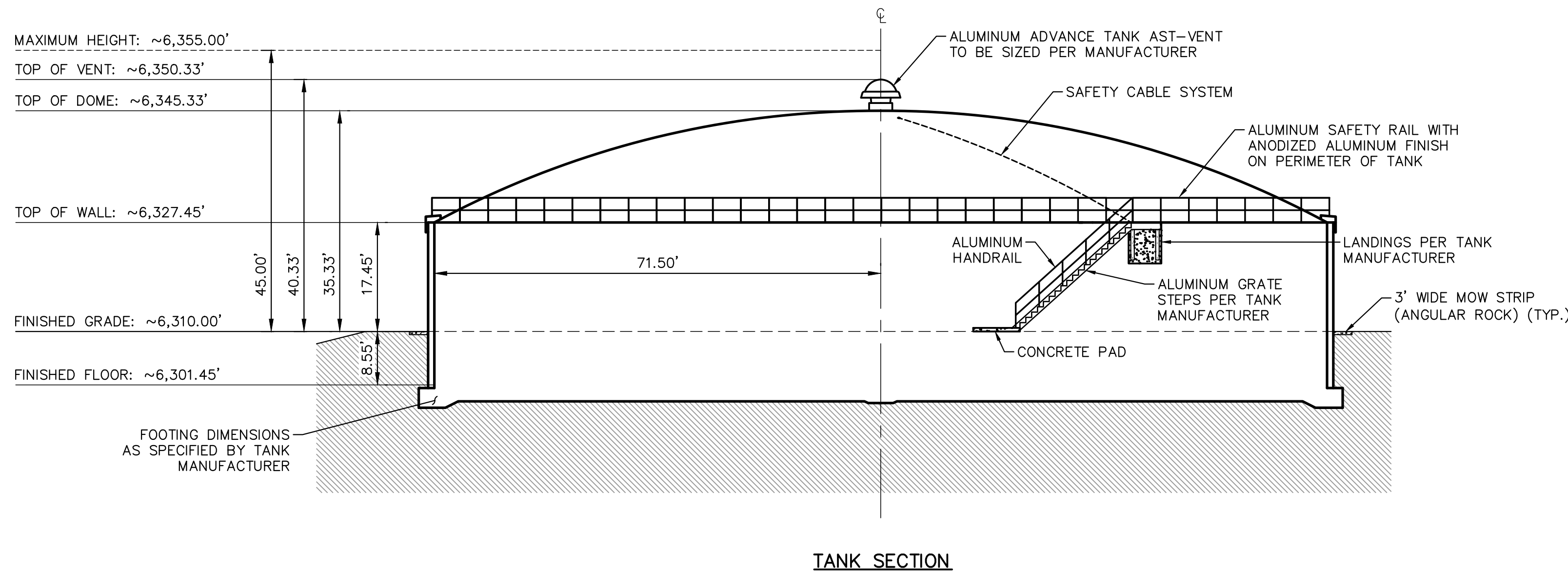
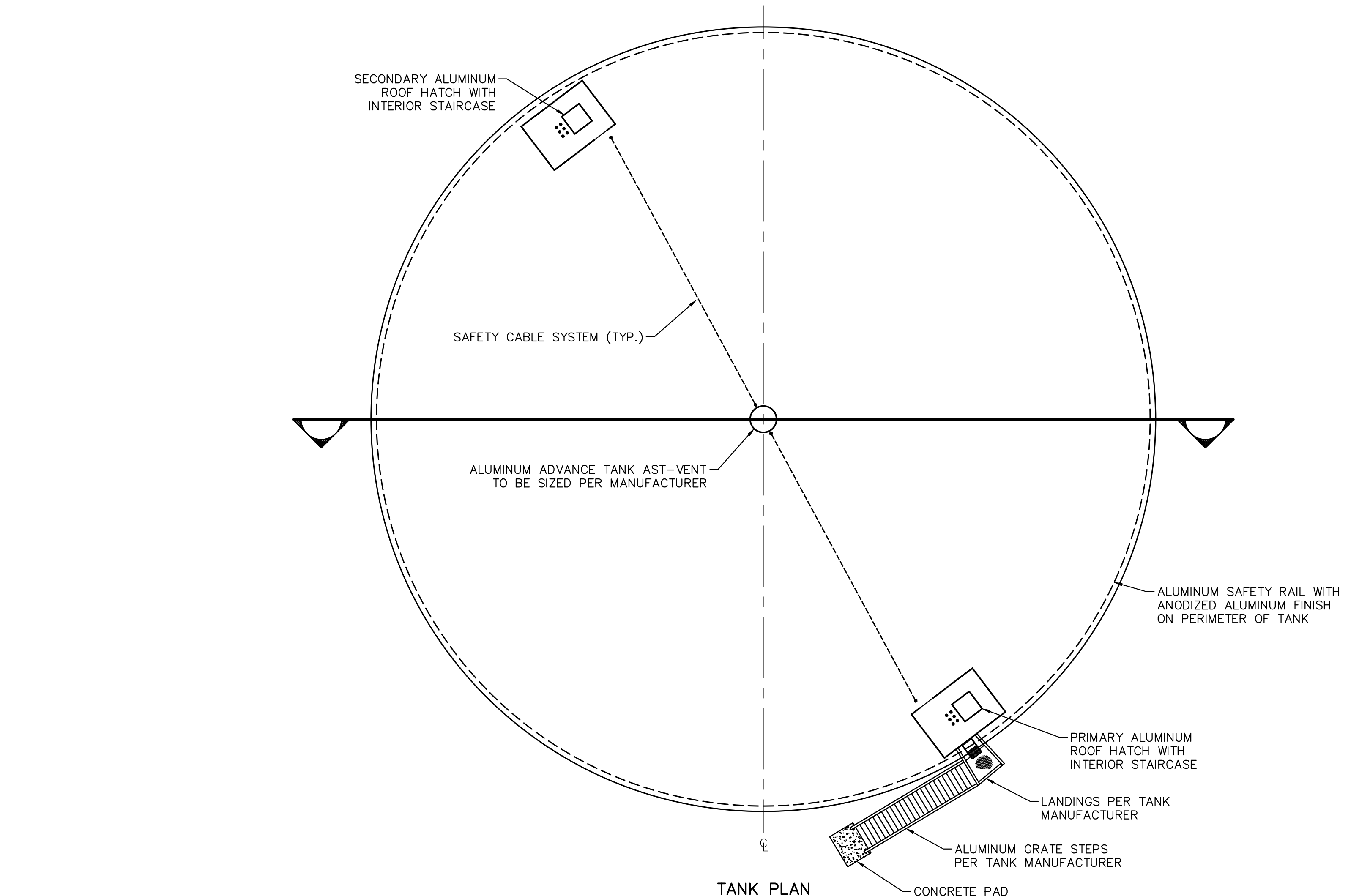

- NOTES:**
1. STAIR DETAILS AND STAIR STRUCTURAL DESIGN, INCLUDING STAIR PAD/LANDING, TO BE PERFORMED BY TANK MANUFACTURER.
 2. TANK STRUCTURE HEIGHT WILL BE CONFIRMED DURING THE CONSTRUCTION PHASE.

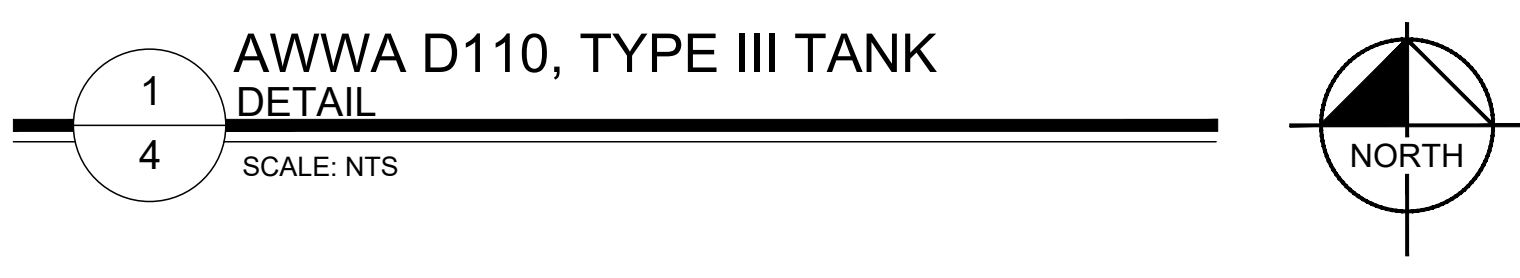

RIDGEGATE TANK
 LOCATION & EXTENT PLAN
 PREPARED FOR
 DOUGLAS COUNTY
 PARKER
 COLORADO

TANK DETAILS

SHEET NUMBER
4

KHA PROJECT
 196231001

DATE
 10/3/2024

SCALE
 AS SHOWN

DESIGNED BY
 MLC

DRAWN BY
 ASD

CHECKED BY
 ATM

© 2024 KIMLEY-HORN AND ASSOCIATES, INC.
 WWW.KIMLEY-HORN.COM PHONE: 303-228-2300
 6200 SOUTH SYRACUSE, SUITE 300, GREENWOOD VILLAGE, CO 80111

PRELIMINARY
 FOR REVIEW ONLY
 NOT FOR
 CONSTRUCTION

 Kimley-Horn and Associates, Inc.

ParkerWater
 & SANITATION DISTRICT

Plotted By: DeFries, Austin, Sheet Set: PWSD L&E, Layout: DETAILS II, October 03, 2024, 04:24:58pm, K:\DEN WaterResources\196231001_PWSD Ridgeway Tank\CADD\PlanSheets\L&E\C-TANK DETL L&E.dwg
 This document, together with the concepts and designs presented herein, is an instrument of service, is intended only for the specific purpose and client for which it was prepared. Reuse of and improper reliance on this document without written authorization and adaptation by Kimley-Horn and Associates, Inc. shall be without liability to Kimley-Horn and Associates, Inc.

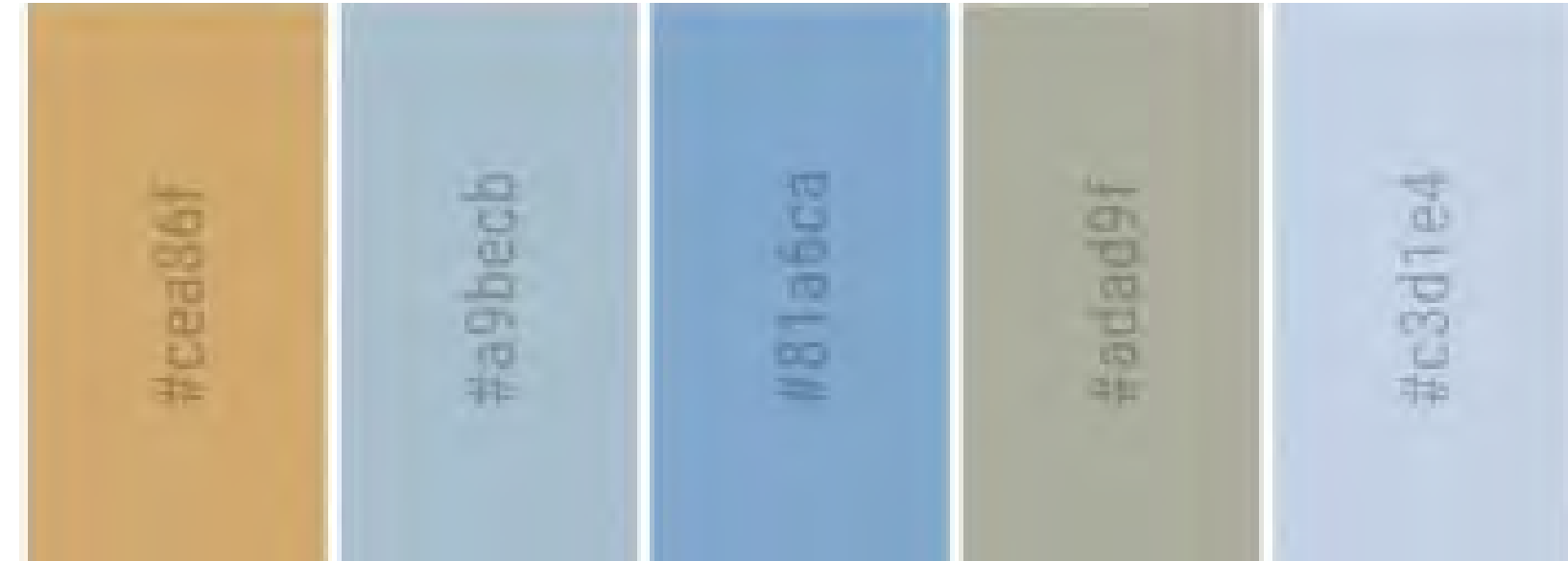

NOTE:
 1. PWSD IS EXPLORING THE IDEA OF PAINTING AN ART MURAL AROUND THE SIDES AND POTENTIALLY THE TOP OF THE TANK. THE MURAL WOULD DEPICT NATURAL THEMES SUCH AS WESTERN LANDSCAPES AND/OR LOCAL PLANTS AND ANIMALS. THE COLOR PALETTE WOULD BE SELECTED TO BLEND IN WITH THE SURROUNDING LANDSCAPE. IF APPROVED BY THE COUNTY AND IF PWSD ELECTS TO MOVE FORWARD WITH THIS ART INSTALLATION, THE FINAL ARTWORK AND COLOR SELECTION WOULD BE DETERMINED IN CONJUNCTION WITH THE CHOSEN ARTIST.

1
TANK FINISH ALTERNATIVES (MURAL COLORS)
 DETAIL
 SCALE: NTS

CONCRETE TANK FINISH		
ALTERNATIVE	COLOR ID	COLOR SAMPLE
#1	NAVAJO	
#2	SUMMER	

NOTES:
 1. TANK COLORS WILL BE MANUFACTURED AND APPLIED ACCORDING TO TAMMSCOAT SPECIFICATIONS.
 2. CONTRACTOR SHALL PROVIDE SAMPLES OF EACH MATERIAL/COLOR SHOWN TO OWNER FOR APPROVAL PRIOR TO ORDERING BUILDING MATERIALS.

2
TANK FINISH ALTERNATIVES (SOLID COLOR)
 DETAIL
 SCALE: NTS

© 2024 KIMLEY-HORN AND ASSOCIATES, INC.
 WWW.KIMLEY-HORN.COM PHONE: 303-228-2300
 6200 SOUTH SYRACUSE, SUITE 300, GREENWOOD VILLAGE, CO 80111

PRELIMINARY
 FOR REVIEW ONLY
 NOT FOR
 CONSTRUCTION

KHA PROJECT	196231001
DATE	10/3/2024
SCALE	AS SHOWN
DESIGNED BY	MLC
DRAWN BY	ASD
CHECKED BY	ATM

TANK DETAILS

RIDGEGATE TANK

LOCATION & EXTENT PLAN

PREPARED FOR

DOUGLAS COUNTY

COLORADO

PARKER

SHEET NUMBER

5

Plotted By: DeFries, Austin, Sheet Set: PWS&D L&E, Layout: DETAILS III, October 03, 2024, 04:25:04pm, K:\IDEN_WaterResources\196231001_PWS&D_Ridgegate_Tank\CADD\PlanSheets\L&E\C-TANK DETAIL L&E.dwg
 This document, together with the concepts and designs presented herein, is an instrument of service, is intended only for the specific purpose and client for which it was prepared. Reuse of and improper reliance on this document without written authorization and adaptation by Kimley-Horn and Associates, Inc. shall be without liability to Kimley-Horn and Associates, Inc.

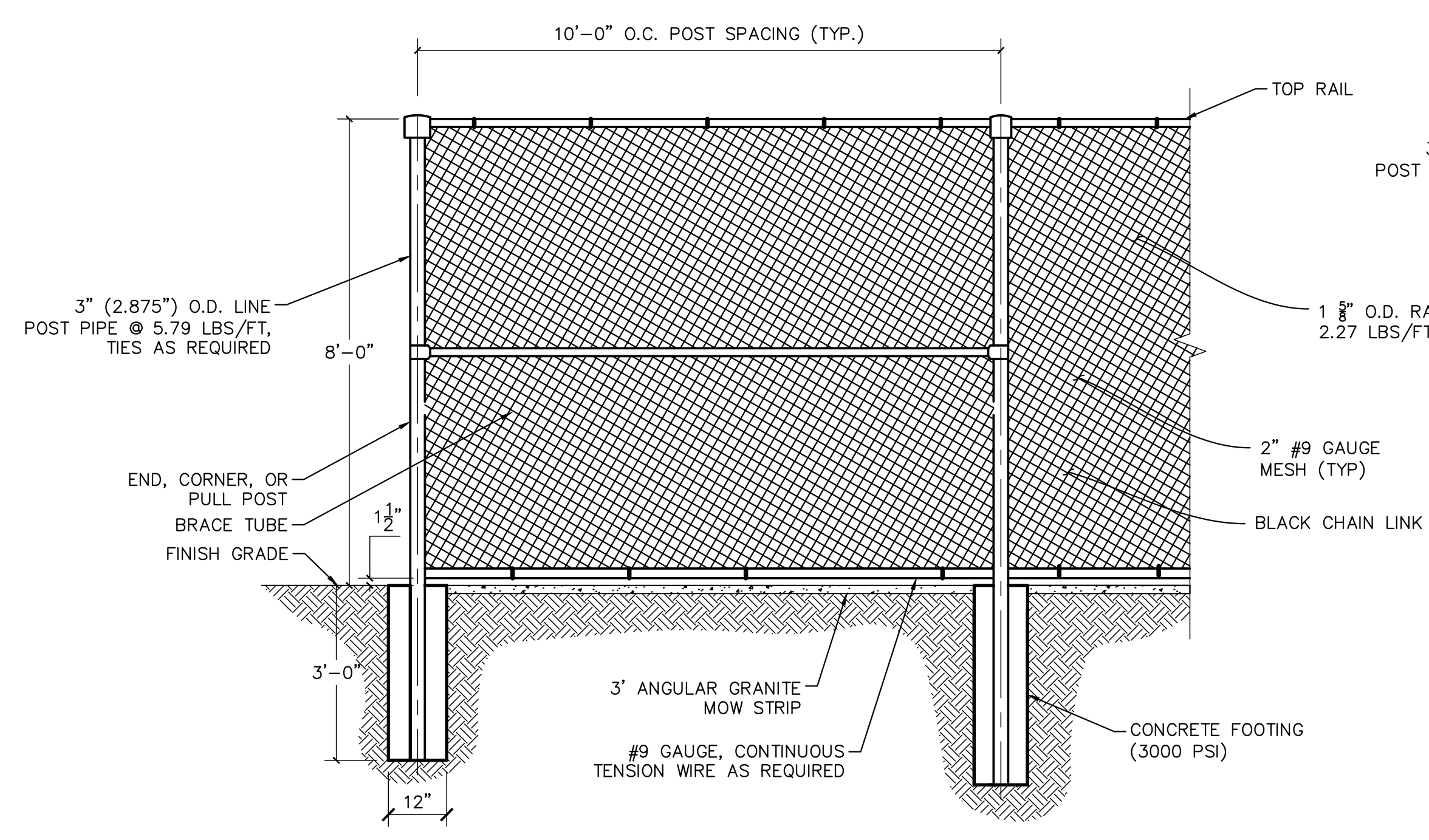

NOTE:
 1. CONTRACTOR SHALL PROVIDE PHYSICAL SAMPLES OF EACH MATERIAL/COLOR SHOWN TO OWNER FOR APPROVAL PRIOR TO ORDERING BUILDING MATERIALS.

1
CHAIN LINK FENCE
DETAIL
 SCALE: NTS

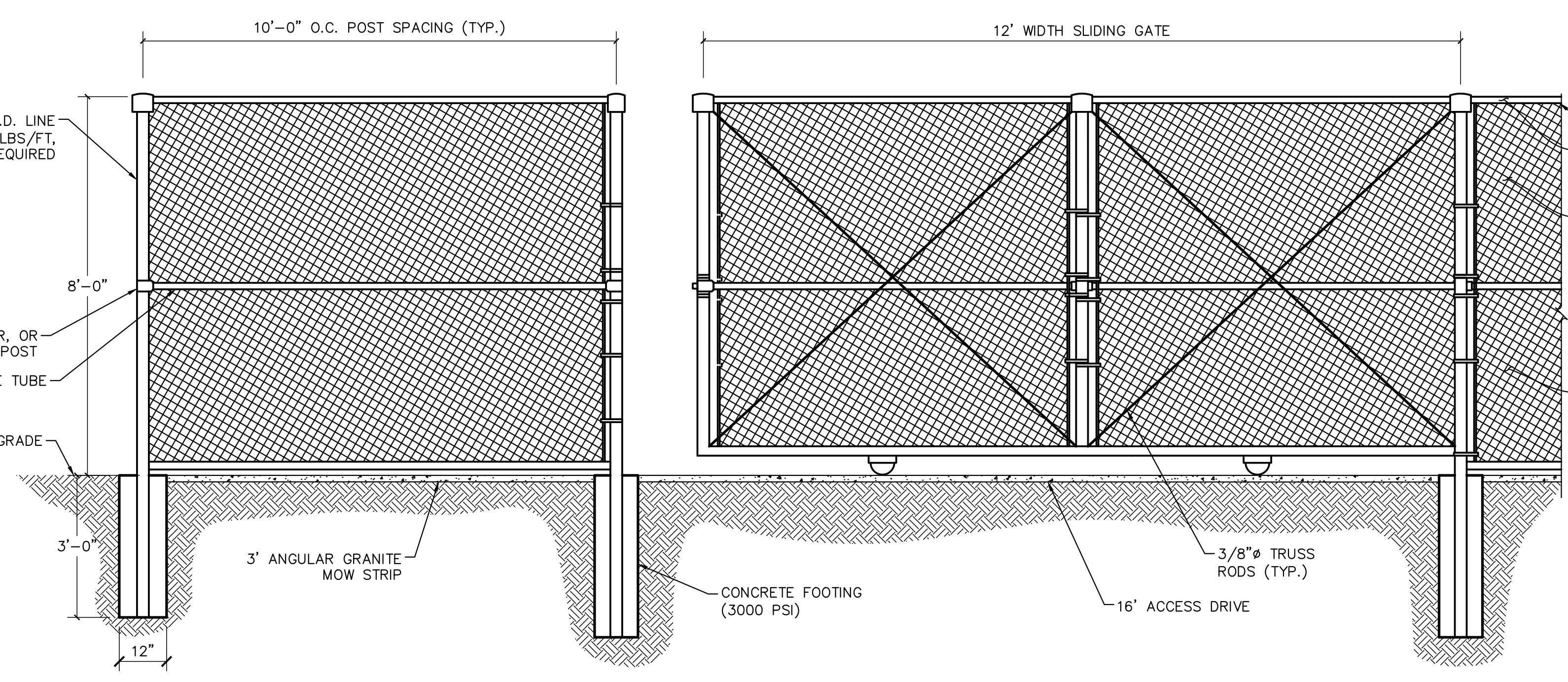

NOTE:
 1. CONTRACTOR SHALL PROVIDE PHYSICAL SAMPLES OF EACH MATERIAL/COLOR SHOWN TO OWNER FOR APPROVAL PRIOR TO ORDERING BUILDING MATERIALS.

2
12' CANTILEVER GATE
DETAIL
 SCALE: NTS

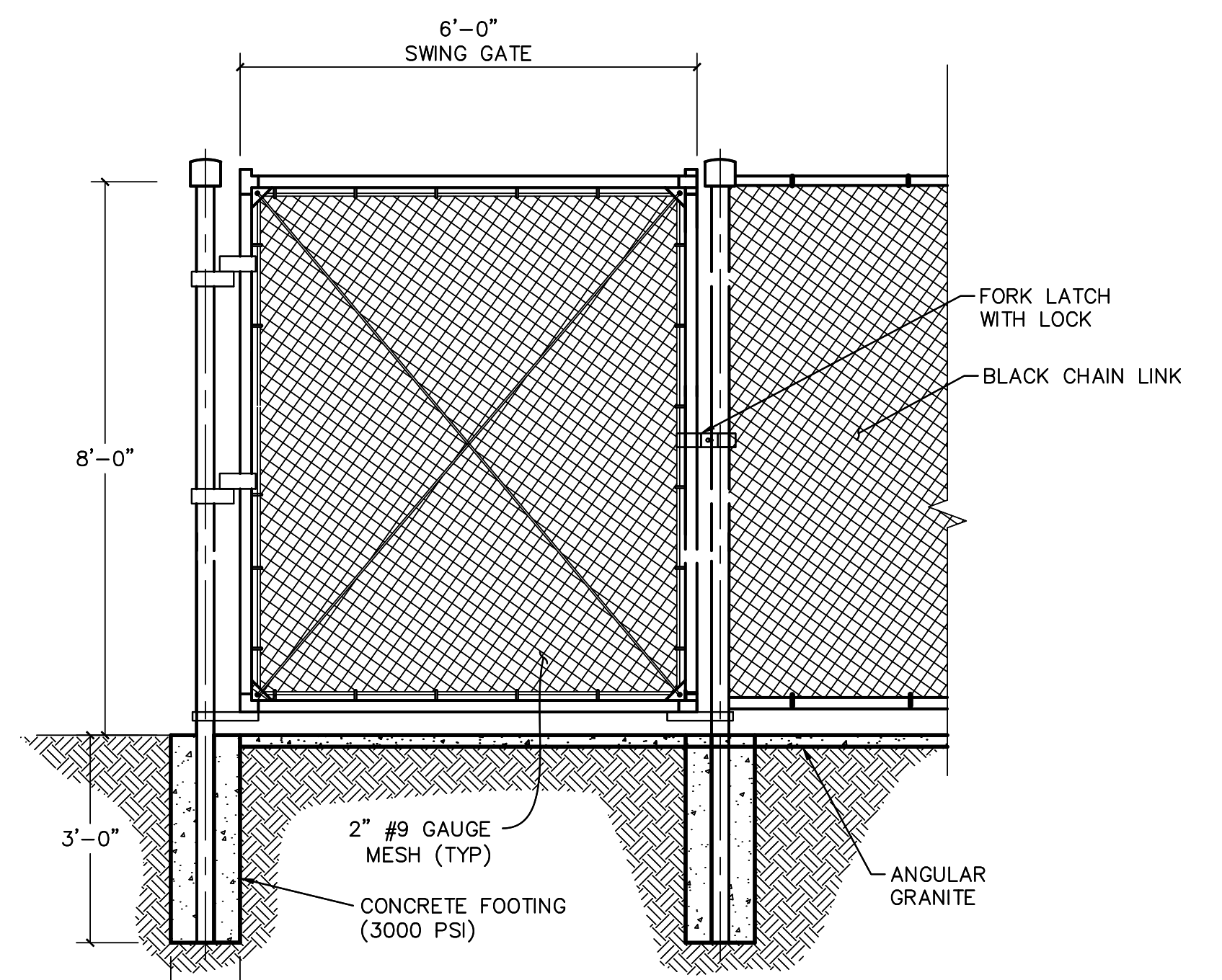

NOTE:
 1. CONTRACTOR SHALL PROVIDE PHYSICAL SAMPLES OF EACH MATERIAL/COLOR SHOWN TO OWNER FOR APPROVAL PRIOR TO ORDERING BUILDING MATERIALS.

3
6' SWING GATE
DETAIL
 SCALE: NTS

ParkerWater & SANITATION DISTRICT

Kimley»Horn
 © 2024 KIMLEY-HORN AND ASSOCIATES, INC.
 WWW.KIMLEY-HORN.COM PHONE: 303-228-2300
 6200 SOUTH SYRACUSE, SUITE 300, GREENWOOD VILLAGE, CO 80111

PRELIMINARY

FOR REVIEW ONLY
NOT FOR CONSTRUCTION

Kimley»Horn
Kimley-Horn and Associates, Inc.

KHA PROJECT 196231001	DATE 10/3/2024	SCALE AS SHOWN	DESIGNED BY MLC
			ASD
			ATM
DRAWN BY		CHECKED BY	

RIDGEGATE TANK
 LOCATION & EXTENT PLAN
 PREPARED FOR
 DOUGLAS COUNTY

COLORADO
 PARKER

SHEET NUMBER
6

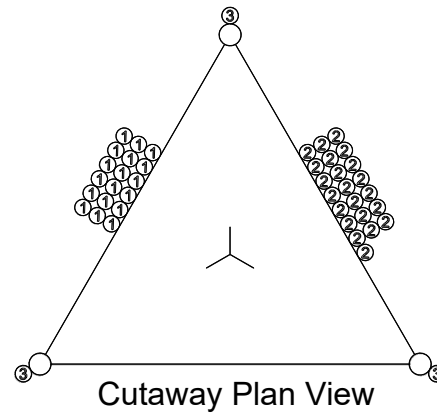
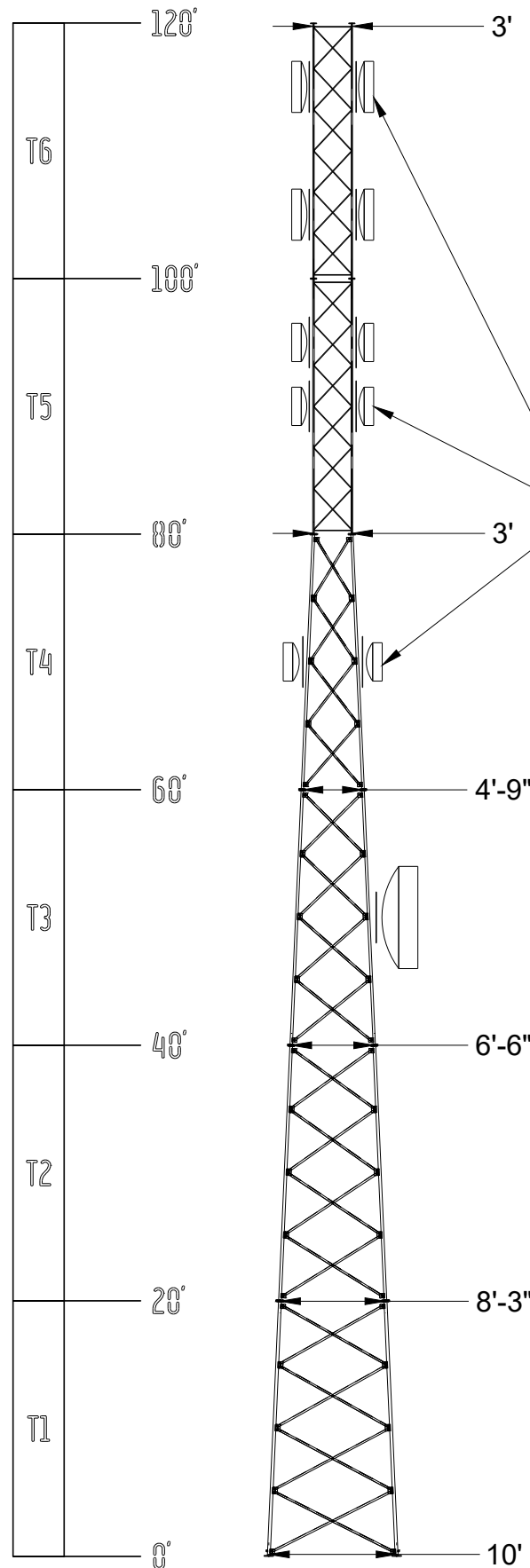

See "Antenna Information" table for equipment sizes and elevations

Notes:

- The notice for the communication tower was filed on August 8, 2024. Notice of preliminary findings were received on September 11, 2024, stating that a 2C certified survey was needed to confirm location and flight approach slope before a favorable determination can be written. The survey is currently underway, once submitted to the FAA it will be reviewed and the notice will be open for public comment for 37 days.
- Once the public comment period is closed, the FAA will determine the overall allowable height of the communications tower and any additional requirements, such as lighting, that are needed to construct the tower.
- The proposed tower will be colored with a galvanized zinc coating unless the FAA determines that it will be required for it to be painted. In the event they do decide that the tower will be painted in aviation orange and white paint with alternating bands of a width of 1/7th of the total tower height or approximately 17 feet each.
- Tower foundation size or type (Matt or Pad and Pier) has not been determined yet. Waiting on final determination from FAA.
- The tower, even though 120ft in the drawing, will be taller due to the foundation height, grout under legs, lightning rod, and possible lighting if required by the FAA. The maximum height of tower will be 130 Ft or less with the above-mentioned items pending the final approval of the FAA.

Member Information							
Section	Elevation	Btm Face	Top Face	Leg Dia.	Diagonals	Girts	# of Bays
1	0' - 20'	10'-0"	8'-3"	S.R. 2-3/4"	L 1 3/4" x 3/16"	N/A	4 - X
2	20' - 40'	8'-3"	6'-6"	S.R. 2-1/2"	L 1 3/4" x 1/8"	N/A	4 - X
3	40' - 60'	6'-6"	4'-9"	S.R. 2-1/4"	L 1 3/4" x 1/8"	N/A	4 - X
4	60' - 80'	4'-9"	3'-0"	S.R. 2-1/4"	L 1 1/2" x 1/8"	N/A	4 - X
5	80' - 100'	3'-0"	3'-0"	S.R. 1-1/2"	S.R. 5/8"	S.R. 5/8"	6 - X
6	100' - 120'	3'-0"	3'-0"	S.R. 1-1/4"	S.R. 5/8"	S.R. 5/8"	6 - X

Antenna Information		
ELEVATION	ANTENNA	LINE
115'	(2) 4' HP DISH	(4) CAT 5
105'	(2) 4' HP DISH	(4) CAT 5
95'	(2) 3' HP DISH	(4) CAT 5
90'	(2) 3' HP DISH	(4) CAT 5
70'	(2) 3' HP DISH	(4) CAT 5
50'	(1) 8' HP DISH	(2) CAT 5

Design Notes:

- TOWER LEGS ARE CONSTRUCTED OF SLOID ROUND BAR MATERIAL
- SOLID ROUND 0.75" AND LARGER SHALL BE MIN. 50KSI YIELD STRENGTH
- SOLID ROUND 0.625" AND SMALLER SHALL BE MIN. 36KSI YIELD STRENGTH
- ALL ANGLE MATERIAL IS MIN. 50KSI YIELD STRENGTH
- ALL BRACE AND FLANGE BOLTS ARE A325-X
- THIS TOWER IS DESIGNED FOR STEP BOLTS UP ALL LEGS TO 40FT, THEN 1 LEG THE FULL HEIGHT FOR CLIMBING WITH SAFETY DEVICE
- (6) Ø1" x 3'-6" LONG (f1554-GR. 105) ANCHOR BOLTS PER LEG.
- THIS TOWER IS DESIGNED FOR A 90M.P.H. WIND SPEED WITH NO ICE AND A 50M.P.H. WIND WITH 0.25" OF ICE IN ACCORDANCE WITH THE TIA/EIA-222-G STANDARD. ICE IS CONSIDERED TO INCREASE IN THICKNESS WITH HEIGHT.
- DEFLECTIONS BASED ON A 60M.P.H. WIND.
- TOWER IS DESIGNED TO EXPOSURE C: STRUCTURE CLASS II" TOPO. CAT 1.

Ridgegate 120ft Self Support Tower v15

Sheet Description		Rev
Drawn By: Clay Calkins	Notes:	
Checked By:		
Approved By:		
1:160	7086.261 lbmass	PAGE: 1/3





Why Choose the 5G-LTE Series?

The 5G-LTE series enclosure is the new evolution and standard for outdoor equipment racking applications. Being constructed of our Alumiflex® material, you'll find it noticeably lighter than steel, yet strong enough to rack even the heaviest equipment. We have taken everything that was great about the LTEE and made it better. With the 5G-LTE, you will continue to find all the standard features you need including, HVAC climate control, electrical load panel, and spool-up, side-box, but we didn't stop there. We have added extra battery tray support for the increasing needs of battery backup; reversable 19" or 23" rack rails, using our versatile "R-strut system"; improved the security and sealing ability of the 3-point locking system to give greater security and weather protection, making this a superb battery enclosure. Again, and again, DDB leads the way with advanced design and features that just work. All while being the most competitively priced and readily available enclosure on the market. Put DDB's substantial stock to work for you today. Contact our professional staff to assist you with your made-to-order solution.



Features

- 0.125" Aluminum Construction
- Stainless Steel External Hardware/Hinge
- 3 Point Lock System
- Heavy Duty Out-Door Construction
- Front and Rear Access
- Flexible and Scalable
- 15 Year Warranty
- Quick Shipping

Application Types

- Telecommunications
- Wireless/Broadband
- Fiber Optics
- Back Haul
- Public Safety
- Utility
- Base Station
- Military
- Wi-Fi
- LTEE/4G/5G



Environmental & Safety Ratings:

- ✓ NEMA 3R, IP 24 (battery compartment)
- ✓ NEMA 4, IP 66 (top compartment)
- ✓ ETL listed; Safety Requirements, UL 62368-1:2019 Ed.3, CSA C22.2

Weight and Dimensions

Approximate Exterior Enclosure Dimensions:

81"H x 30"W x 34"D

Shipping Dimensions:

50"W x 60"L - Decked Pallet

Approximate Shipping Weight:

644 lbs.

5G-LTE Enclosure



Made in America
Believing in American
Craftsmanship



Features

1. Alumishield
2. Front & rear 19" or 23" Reversible, Adjustable, Racking Rails, 52 RU's
3. 4-Square Electrical Outlet
4. 3 Point Locking System
5. Powder Coat White
6. Battery Compartment
7. 4000 BTU HVAC
8. Spool-Up Box with cable passthrough holes
9. 8 Space 100 Amp LC
10. 12" copper, ground bar *(inside spool-up box)*
11. Reusable vent filters
12. 50A generator plug
13. 6, I-Hooks for lifting
14. 2, door grounding studs with copper grounding cables
15. 2, 48VDC fans with thermostat *(inside rear door)*
16. R3 Dupont insulation



Installation, operating and safety instructions can be downloaded here



Scan this code for replacement parts



WEB DRAWING (NOT FOR FABRICATION)

REVISIONS		
REV.	DESCRIPTION	DATE
A	WEBSITE DRAWING FOR 5G-LTE	1/9/2020
B	UPDATED WITH N28 PENTAIR A/C	5/12/2020

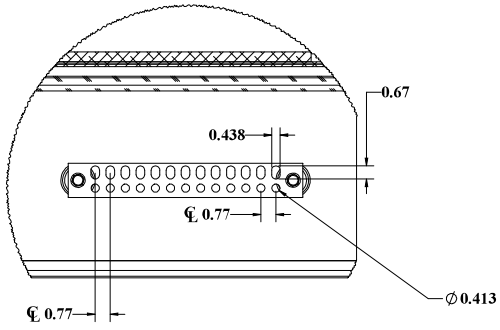

DETAIL D
SCALE 1:3

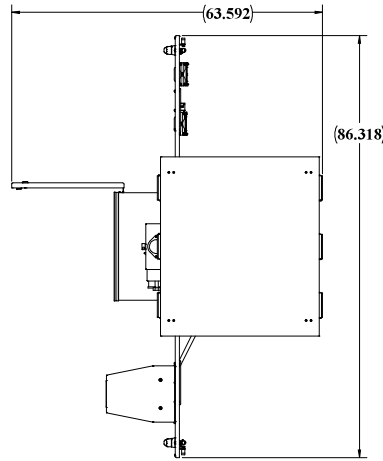

STANDARD WINDLOKS EACH DOOR

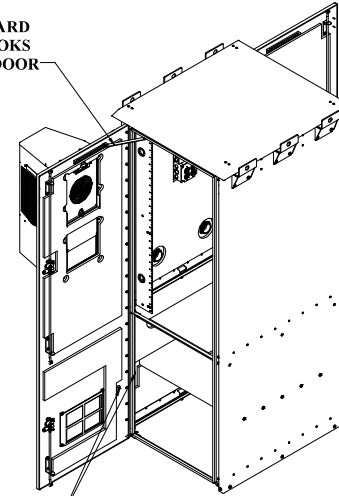

GROUNDING STUD

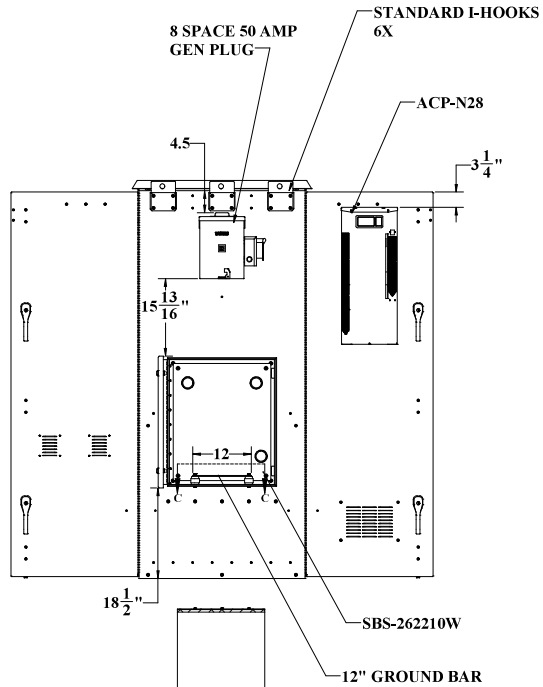

NEMA TYPE 4

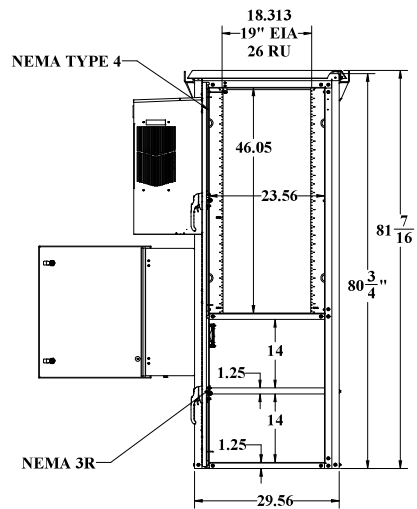

NEMA 3R

3 POINT LOCKING

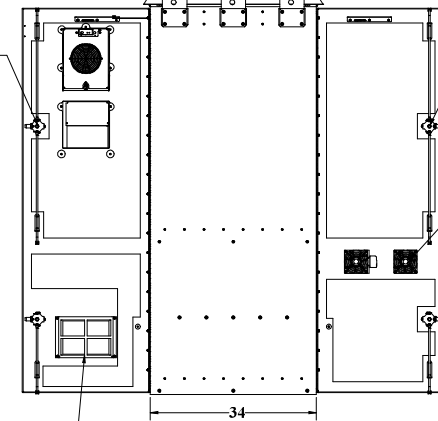

3 POINT LOCKING

48 VOLT FANS

VENTS WITH FILTERS

NEMA 4 (Top Compartment)(Unlisted)
NEMA 3R (Battery Compartment)(Unlisted)
ETL listed to UL Standard 60950-1/CSA 22.2C

UNLESS OTHERWISE SPECIFIED:		NAME	DATE	DDB Unlimited Inc.		
CONTOUR LINE STYLE	Model by: 0008			SCALE:		
APPROVAL	Drawn by: Marcus 01/09/20			SHEET	Cage Code:	DWG. NO.:
APPROVAL	Checked by: Marcus 01/09/20				88515	02200
APPROVAL	Third-Party Checked:					
APPROVAL	Sales Rep/Comp/Off:					
APPROVAL	Q.A. Appr: Mary 01/12/20					
APPROVAL	Prod.Mgr: Charles 05/13/20					
MATERIAL: 304 STAINLESS STEEL/304M	Color/Finish:			SCALE: 1:12	WEIGHT: 47.3 lbs.	SHEET 1 OF 3
PAINT: 4000 ALUMINUM POLYURETHANE	Color/Finish:					
DO NOT SCALE DRAWING						

WEB DRAWING (NOT FOR FABRICATION)

SECTION C-C

UNCLASSIFIED PUBLIC

File Location: (DDB) (PDM) Voadi1
C:\DDB\Drawing Request\Customers\ODS WEB DWG\LEEF\FamA\5G-LTE-0213A\

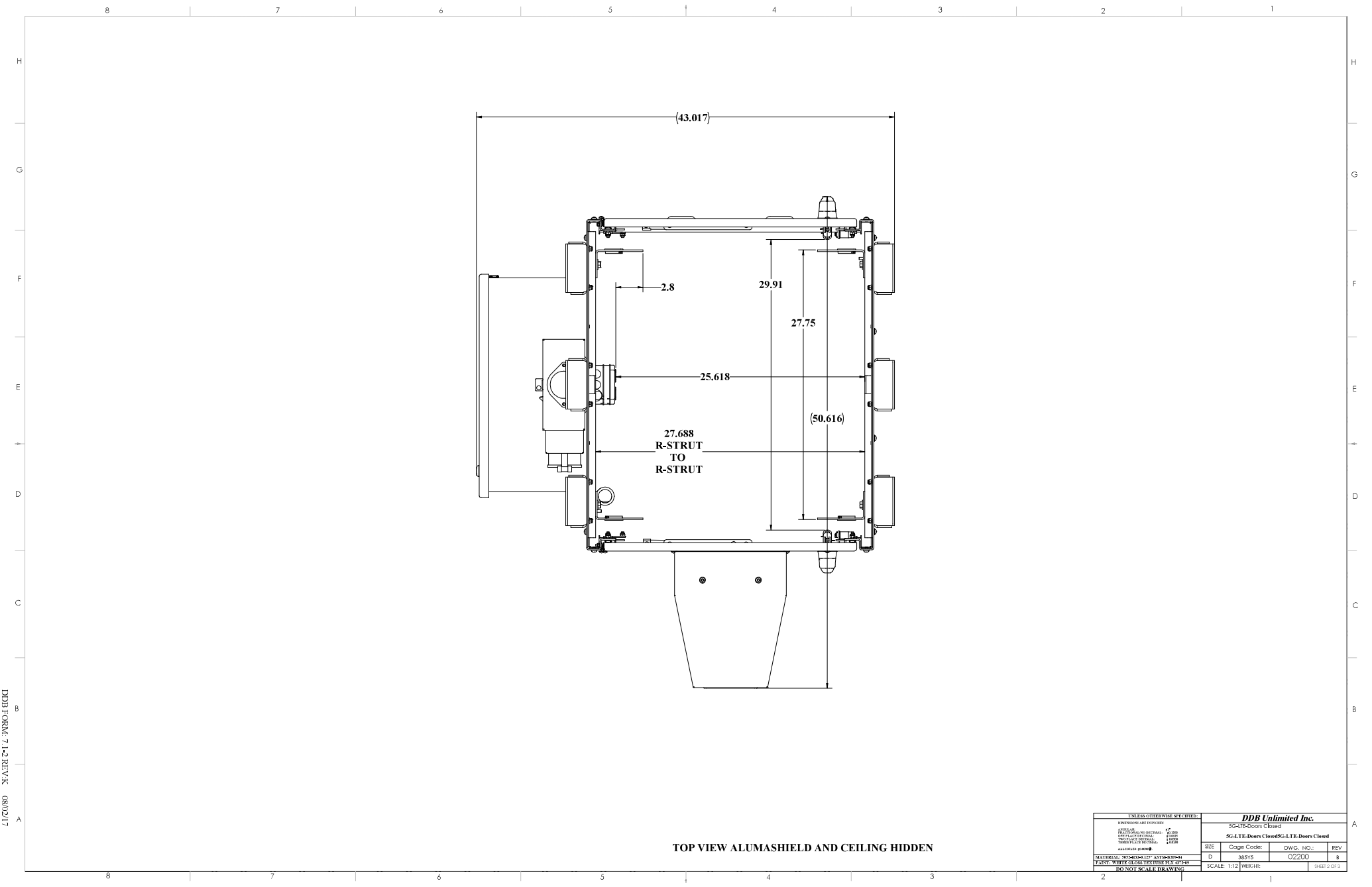

TOP VIEW ALUMASHIELD AND CEILING HIDDEN

UNCLASSIFIED - PUBLIC

UNLESS OTHERWISE SPECIFIED:			
DIMENSIONS ARE IN INCHES			
FINISH	AS SHOWN	1"	25.4
CONCRETE	AS SHOWN	1/8"	3.175
STEEL	AS SHOWN	1/8"	3.175
WOOD	AS SHOWN	1/2"	12.7
GLASS	AS SHOWN	1/4"	6.35
ALL OTHERS	AS SHOWN		
MATERIALS SPECIFIED BY ARCHITECT			
PAINT: WHITE GLASS TEXTURE FLY 115 540			
DO NOT SCALE DRAWING			
DDB Unlimited Inc.		SCALE: 1/8" = 1'-0"	
SCALE: 1/8" = 1'-0"			
REV	Change Code:	DWG. NO.:	REV
D	88515	02200	8
SCALE: 1/12"		WEIGHT:	SHEET 2 OF 3

File Location: (DDB) (EPDM Vault)
 C:\DDB\Drawing Requests\Customers\DDB WEB DWG\LIES-Family\SG-16-0213A\

DDB FORM 7-1-2 REV/AK 08/02/17

WEB DRAWING (NOT FOR FABRICATION)

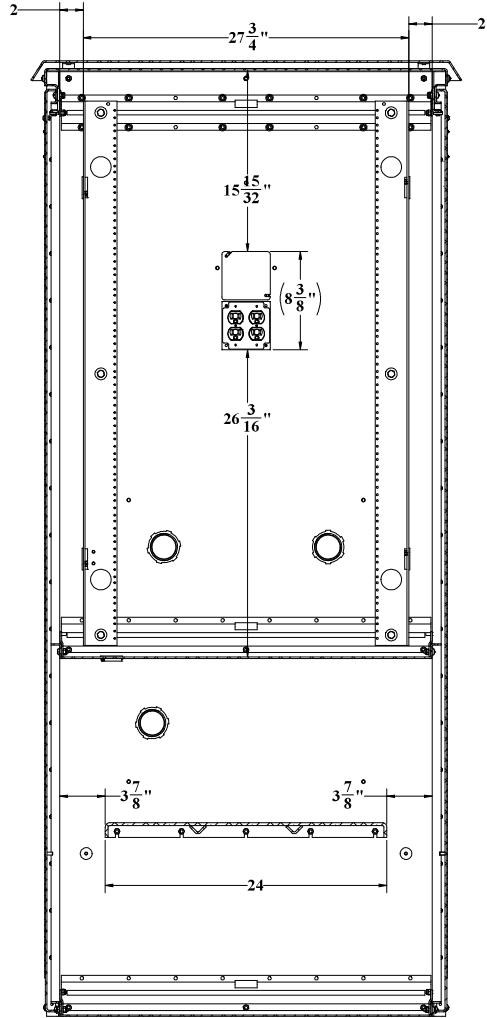

SECTION B-B
SCALE 1:5

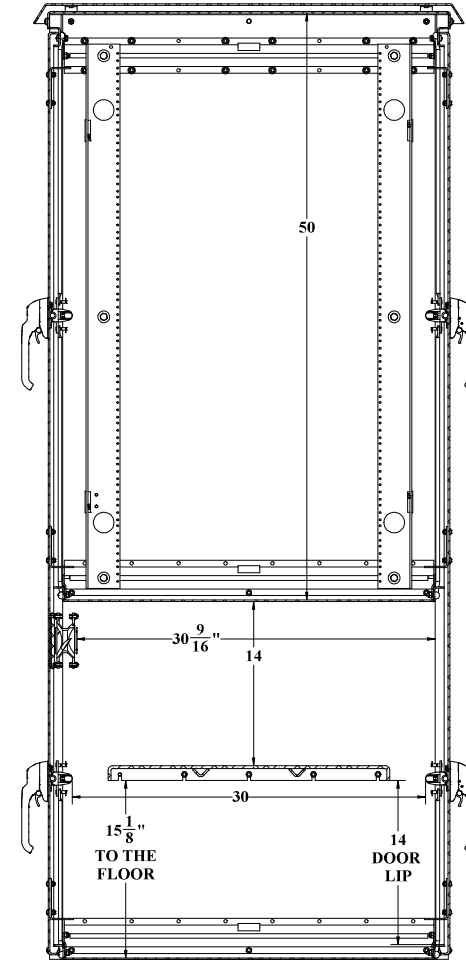
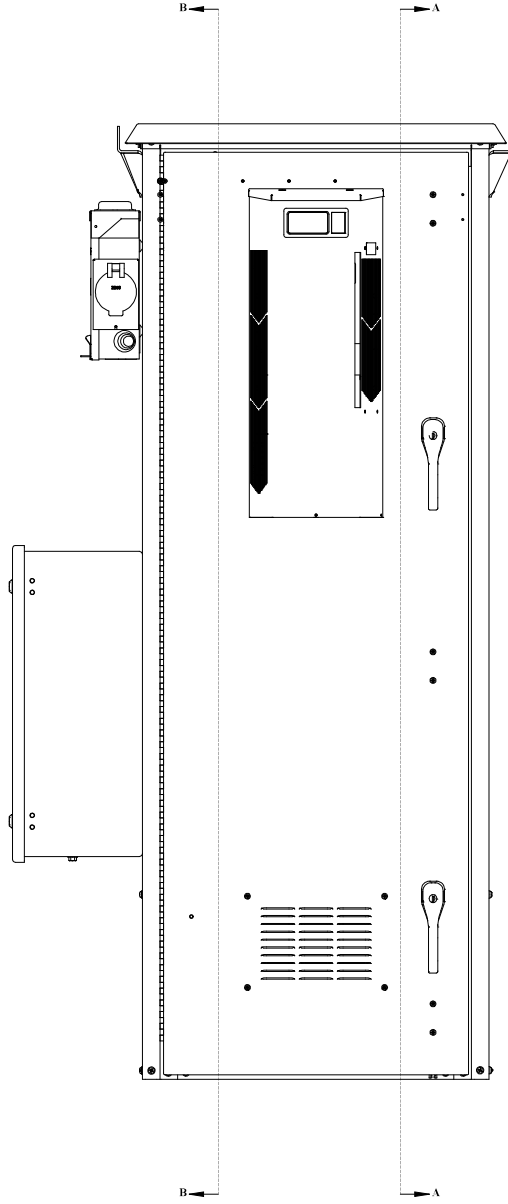

SECTION A-A
SCALE 1:5

WEB DRAWING (NOT FOR FABRICATION)

UNLESS OTHERWISE SPECIFIED:		NAME	DATE	DDB Unlimited Inc.			
CONSTRUCTION AND/OR FINISH	Model No.	5048		504-TE			
APPLICABLE	Drawn By	Manuel	01/09/20	SC-LTE-Doms Closed			
APPLICABLE	Checked By	Manuel	01/09/20				
APPLICABLE	Third-Party Approval	Sales Rep./w/ Oversight					
APPLICABLE	Q.A. Appr.	Mary	01/12/20	SHE	Cage Code:	DWC. NO.:	REV
APPLICABLE	Prod. Mgr.	Chad	01/12/20	D	38515	02200	B
FABRICATION	Material	304 STAINLESS STEEL/304HAT	Sheet No.	SCALE: 1:1a	WEIGHT:	SHEET 3 OF 3	
DO NOT SCALE DRAWING							

UNCLASSIFIED PUBLIC

File Location: (DDB) (PDM) Vauldri
C:\DDB\Drawing Request\Customers (DDB) WEB-DWG-LEEF-Fam\SC-LTE-02134A



ThinAir Communications (ThinAir) proposes that the Ridgeway tower site be constructed as shown in the example photo below. The base of the tower will be triangular in shape tapering as the tower increases in height. The face of the tower base is approximately 10 feet from the center of each tower leg.

The tower in the picture below is an example of a galvanized zinc coating. This will be the same coating used on the proposed tower unless the FAA determines that it will require for it to be painted. In the event they do decide that, the tower will be painted in aviation orange and white paint with alternating bands of a width of $1/7^{\text{th}}$ of the total tower height or approximately 17 feet each.



Vertically Polarized, Omni-Directional / 10 dBd

BCD-87010 ___ 25%

When ordering, replace "___" with connector type.

Mechanical specifications

Length		
Overall	3393 mm	134 in
Radome	2893 mm	114 in
Diameter	Ø65 mm	2.6 in
4) Weight	12 kg	26.5 lbs
Wind Area	0.2 m ²	2.4 ft ²
Wind load at 50 m/s	351 N	79 lbs

Antenna consisting of aluminum alloy. Dipoles covered by a polyurethane painted fiberglass radome. **Inverted models available.**

Mounting

Support Pipe: Aluminum alloy diameter Ø70 mm (2.76 in), length 500 mm (19.7 in).

Mounting bracket kit #36312000 Standard -or- #36413001 Offset

Downtilt bracket kit N/A

Electrical specifications

Frequency Range	870-960 MHz
Impedance	50Ω
3) Connector	NE, E-DIN
1) VSWR	≤1.43:1
Polarization	Vertical
1) Gain	10 dBd
2) Power Rating	500 W
1) Half Power Angle	
H-Plane	360°
E-Plane	7°
1) Lobe Tilt	1.25°
1) Null Fill	25%
Lightning Protection	Direct Ground

Radiation-pattern¹⁾

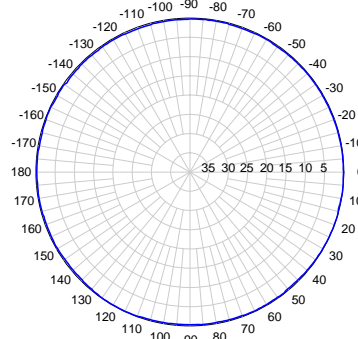

Horizontal

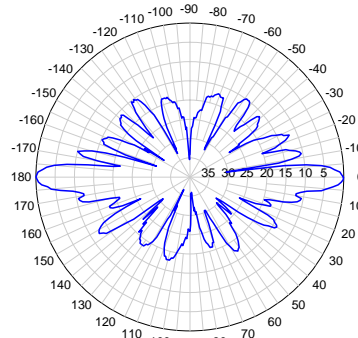

Vertical



806-960 MHz



Amphenol Antel's Exclusive 3T (True Transmission Line Technology) Antenna Design:

- A 1 1/4" four-channel extrusion running the entire length of the antenna for unmatched strength and rigidity.
- Durable brass feedline design that eliminates the need for conventional solder joints in the signal path.
- A non-collinear system with access to every radiating element for broad band width and superior performance.
- Air as insulation for virtually no internal signal loss.

Every Amphenol Antel antenna is under a five-year limited warranty for repair or replacement.

Inverted Models Available.

¹⁾ Typical Values
²⁾ Power Rating limited by connector only.
³⁾ NE indicates an elongated N Connector.
 E-DIN indicates an elongated DIN Connector.
⁴⁾ The antenna weight listed above does not include the bracket weight.

Improvements to mechanical and/or electrical performance of the antenna may be made without notice.

870-960 MHz



Revision Date: 2/11/04



Outdoor Remote Power Systems

Features

- Complete 720W Remote Power Solution for Off-Grid Operation.
- Supports up to 157W continuous power with 6hrs peak sun.
- Weatherproof Outdoor Enclosures with up to 720Ah Battery
- Expandable Ground Mounted Solar Mount
- High Performance Sealed Lead Acid AGM Batteries
- MPPT Solar Charge Controllers with RS485 Interface
- Thermostatically Controlled Ventilation



RPSTL 720W
Solar System

Applications

- Wireless Base Stations
- Remote Lighting
- Surveillance Cameras
- Wireless Bridge and Repeaters
- Off-Grid Power
- Backup Power

Description

The RemotePro® 720W Series outdoor power systems are designed for applications that require a primary off-grid power source to run various equipment. The vented weatherproof enclosures have generous space available inside for mounting customer equipment. Multiple mounting brackets are welded inside the enclosure for mounting DIN rails or flat plates.

The systems are available with MPPT temperature compensated solar charge controllers with an RS485 interface for remote monitoring with a Tycon TPDIN-Monitor-WEB3 or TP-SC-WIFI adapter. The RPAL48 has a 48V MPPT with 7 port GigE PoE switch and various controls for email alerts and remote monitoring. The solar controllers turn off the load automatically if the battery voltage drops too low, in order to preserve battery life. The load turns on automatically once the battery voltage recovers.



The outdoor enclosures are powder coated steel pole mount or diamond plate aluminum ground mount. They are hinged and gasket sealed with locking closures. They have cable gland ports for CAT5/6 cable, antenna cables/connectors or other cabling. Included is a thermostatically controlled fan assembly which turns on automatically when the temperature exceeds 45°C. The high quality solar panels have a 25 year power output guarantee and a +5W output tolerance.

Batteries are a Non-Spillable Valve Regulated Sealed Lead Acid Advance Glass Matt (AGM) type which have excellent temperature and deep discharge performance. Expected battery life exceeds 5 years.

The systems come with all cabling required to connect the batteries to the controller and 20' outdoor rated cable to connect the solar panels to the controller.

The solar mount includes the concrete anchors that are necessary for mounting. Tilt adjustment range is 10-65 deg and can be adjusted by one person. The mount can be expanded to hold 4 panels (Kit # TP5M-350x4-AdapterKit) or 6 panels (Kit# TP5M-350x6-AdapterKit). This is useful if more solar capacity is needed in the future.

Specifications – Controller Specific

	12/24 MPPT	12/48 MPPT	48V MPPT/PoE Switch
Controller Type	MPPT with display and RS485		Manageable MPPT with 7 port GigE PoE Switch. Remote Monitoring.
Controller Outputs	20A or 30A Wire Terminal		4 Port 802.3at or 24V Passive, 3 Port 24/48V 30W Passive PoE. Aux Port 24/48V 2.5A
Bulk Charge	14.4V @ 12V Battery 28.8V @ 24V Battery	14.4V @ 12V Battery 28.8V @ 24V Battery 57.6V @ 48V Battery	57.6V @ 48V Battery
Float Charge	13.8V @ 12V Battery 27.6V @ 24V Battery	13.8V @ 12V Battery 27.6V @ 24V Battery 55.2V @ 48V Battery	55.2V @ 48V Battery
Over-discharge protection	11.1V @ 12V Battery 22.2V @ 24V Battery	11.1V @ 12V Battery 22.2V @ 24V Battery 44.4V @ 48V Battery	44.4V @ 48V Battery (user settable)
Over-discharge recovery volts	12.6V @ 12V Battery 25.2V @ 24V Battery	12.6V @ 12V Battery 25.2V @ 24V Battery 50.4V @ 48V Battery	50.4V @ 48V Battery (User Settable)
Controller Self Consumption	<1W	<1W	<3.5W
			

Specifications – Enclosure Specific

	RPSTL	RPAL
Battery Type	Maintenance Free, Non-Spillable, Valve Regulated Sealed Lead Acid, AGM	Maintenance Free, Non-Spillable, Valve Regulated, Sealed, Pure Lead Carbon AGM
Battery Life	5+ years	
Enclosure Type	ENC-STL-24x24x16 Pole/Wall Mount, Powder Coat Steel	ENC-AL-65x18x20 Ground Mount, Diamond Plate Aluminum
Enclosure Size	23.9 x 23.9 x 16.1" (608 x 608 x 409.5mm)	65 x 18 x 20" (1651 x 457 x 508mm)
Internal Mount Features	DIN Rail/Flat Plate Mounting Brackets Welded to Door and Back	
Solar Panel Dims (L x W x T)	720W Solar Array 78 x 77 x 1.6" (1980 x 1956 x 40mm)	
Operating Temperature	-30°C to +60°C (-22°F to 140°F)	
System Weight (no batteries)	377 lb (171 kg)	394 lb (179 kg)
Battery Weight	40.3 lb (18.3 kg) (Each 50Ah Battery)	127 lb (57.6 kg) (Each 180Ah Battery)
Wind Speed Rating	90MPH	
Warranty	3 Years	



AGM 12V 52Ah Battery



RPSTL Enclosure interior without batteries or controller



AGM 12V 180Ah Battery



RPAL Diamond Plate Aluminum Ground Mount

System Ordering:

Model #	Enclosure Type	Battery Voltage	Battery Capacity @12V	Rated Continuous Power with 6hrs Peak Sun	Backup Time @ Rated Power	Controller Type	Output	Solar Panel Size
RPSTL12/24M-200-720	Large Steel	12/24V	200Ah	50W	>24hrs	12/24 MPPT	12/24V 30A	720W
RPSTL12/24M-400-720	Large Steel	12/24V	400Ah	100W	>24hrs	12/24 MPPT	12/24V 30A	720W
RPSTL12/48M-400-720	Large Steel	12/24/48V	400Ah	100W	>24hrs	12/48 MPPT	12/24/48V 30A	720W
RPAL12/48M-720-720	Ground Mount Aluminum	12/24/48V	720Ah	157W	>24hrs	12/48 MPPT	12/24/48V 30A	720W
RPAL48-720-720	Ground Mount Aluminum	48V	720Ah	157W	>24hrs	48V MPPT with 7 port PoE Switch	24/48V 200W	720W

Part Number Definition:

RPSTL 12/24M-400-720

<u>Enclosure Type</u> S - Small Aluminum L - Large Aluminum STL - Large Steel AL - Ground Mount Alum	<u>Battery Voltage, Ctrl Type</u> 12/24 - 12/24V PWM 12/24M - 12/24V MPPT 12/48M - 12/24/48V MPPT 48 - 48V MPPT with 7 port PoE Switch	<u>12V Storage Capacity</u> 100 - 100Ah 200 - 200Ah 400 - 400Ah 720 - 720Ah 14 - 1.44KAh	<u>Solar Panel Output</u> 85 - 85 Watt 170 - 170 Watt 340 - 340 Watt 720 - 720 Watt
------------------------------------------------------------------------------------------------------------------	----------------------------------------------------------------------------------------------------------------------------------------------------	---------------------------------------------------------------------------------------------------------	-------------------------------------------------------------------------------------------------



RPAL 720W Solar System



720W Solar Mount - 10-65 deg Tilt, ground mount

Available Accessories



TPDIN-Monitor-WEB3 V2
Remote Monitor with
RS485 Interface + TPDIN-
CABLE-485



TP-SC-WIFI
WiFi Adapter
for MPPT

For further information contact:

Tyconsystems.com

