

Staff Report

Date:

To: Douglas County Board of County Commissioners

Through: Douglas J. DeBord, County Manager

From: Terence T. Quinn, AICP, Director of Community Development *TQ*

CC: Luke Thornton, CPRP, Parks Program Coordinator
Nick Giauque, CPRP, Parks Program Manager
Steve Shoultz, CPRE, Assistant Director of Parks, Trails, and Building Grounds

Subject: **AT&T Cell Tower Lease Agreement**

Board of County Commissioners Business Meeting: **March 11, 2025 @ 1:30 p.m.**

I. EXECUTIVE SUMMARY

In 2006, the Board of County Commissioners (Board) entered a lease agreement with Cingular Wireless for a cell tower at Challenger Regional Park. The lease has been renewed three times and is set to expire in 2026. County staff and legal have worked with MD7, AT&T's authorized representative, to develop an amendment to extend the lease.

II. BACKGROUND

The Board entered into a lease agreement with Cingular Wireless in 2006 for a cell tower at Challenger Regional Park. In 2006, AT&T purchased Cingular Wireless and assumed the lease and cell tower. The lease was amended in 2012 to extend the height of the tower and increase the rent. A second amendment in 2014 increased the size of the premises to accommodate a generator. A third amendment in 2017 increased the size of the premises to accommodate equipment changes. The original lease term was set for five years with the option for the Board to extend the lease for three additional terms. The lease was extended and is set to expire in May 2026.

County staff and legal have developed a fourth amendment to extend the lease into the future. Commencing on January 1, 2026, the monthly rent shall be for \$3,300 with an annual four percent increase on January 1st of each subsequent year of the term. The initial term shall be from January 1, 2026, to December 31, 2030. The agreement may be renewed for four successive five-year terms unless the tenant notifies the County of its intention not to renew or the County exercises its right to terminate the agreement.

III. STAFF RECOMMENDATION

Staff recommends that the fourth amendment of the lease agreement between AT&T and Douglas County be approved by the Board of County Commissioners.

ATTACHMENTS

PAGE

Communications Site Lease Agreement_2006.....	3
Communications Site Lease Agreement First Amendment_2012.....	15
Communications Site Lease Agreement Second Amendment_2014.....	24
Communications Site Lease Agreement Third Amendment_2017	41
Communications Site Lease Agreement Fourth Amendment_2025.....	52

Market: Western/Denver
Cell Cite Number: 1431
Cell Site Name: Lincoln & Jordan

COMMUNICATIONS SITE LEASE AGREEMENT

This COMMUNICATIONS SITE LEASE AGREEMENT ("Agreement") is entered into this 21st day of February 2006 ("Effective Date"), by New Cingular Wireless PCS, LLC, a Delaware limited liability company, having a mailing address of 6100 Atlantic Boulevard, Norcross, GA 30071 ("Tenant") and Douglas County, Board of Commissioners, having a mailing address of 100 Third Street, Castle Rock, CO 80104 ("Owner or "Landlord").

For One Dollar (\$1.00) paid to Owner, and other good and valuable consideration the receipt and sufficiency of which is hereby acknowledged, the parties herein agree as follows:

1. **PREMISES**

Owner owns a parcel of land ("Land") and a light pole on a sports complex to be replaced by a pole sufficient to support Owners lights and Tenants communication facility ("Tower") located in the City of Parker, County of Douglas, State of Colorado, commonly known as Challenger Park. The Tower and the Land are collectively referred to herein as the "Property." The Land is more particularly describe in Exhibit A annexed hereto. Subject to the provisions of Paragraph 2 below (Effective Date/Due Diligence Period), Owner hereby leases to Tenant and Tenant leases from Owner approximately 300 square feet of Land and space on the Tower and all access and utility easements necessary or desirable therefore (collectively, the "Premises") as may be generally described in Exhibit B annexed hereto.

2. **EFFECTIVE DATE/DUE DILIGENCE PERIOD.**

This agreement shall be effective on the date of full execution hereof ("Effective Date"). Beginning on the Effective Date and continuing until the Term Commencement Date as defined in Paragraph 3 below ("Due Diligence Period"), Tenant shall only be permitted to enter the Property for the limited purpose of making appropriate engineering and boundary surveys, inspections, and other reasonably necessary investigations and signal, topographical, geotechnical, structural and environmental tests (collectively, "Investigations and Tests") that Tenant may deem necessary or desirable to determine the physical condition, feasibility and suitability of the Premises. Upon Tenant's request, Owner agrees to provide promptly to Tenant copies of all plans, specifications, surveys, and Tower maps for the Land and Tower. The Tower map shall include the elevation of all antennas on the Tower and the frequencies upon which each operates. In the event that Tenant determines, during the Due Diligence Period, that the Premises are not appropriate for Tenant's extended use, Tenant shall have the right to terminate this Agreement without penalty upon written notice to Owner at any time prior to the Term Commencement Date. Owner and Tenant expressly acknowledge and agree that Tenant's access to the Property during this Due Diligence Period shall be solely for the limited purpose of performing the Investigations and Tests, and that Tenant shall not be considered an owner or operator of any portion of the Property, and shall have no ownership or control of any portion of the Property (except as expressly provided in this Paragraph 2), prior to the Term Commencement Date.

3. **TERM.**

The term of Tenant's tenancy hereunder shall commence upon the start of construction of the Tenant Facilities (as defined in Paragraph 6 below) or eighteen (18) months following the Effective Date, whichever first occurs ("Term Commencement Date") and shall terminate on the fifth anniversary of the Term Commencement Date (the "Term") unless otherwise terminated as provided herein. Tenant shall have the right to extend the Term for three (3) successive five (5) year periods (the "Renewal Terms") on the same terms and conditions as set forth herein. This Agreement shall automatically be extended for each successive Renewal Term unless Tenant notifies

Landlord of its intention not to renew prior to commencement of the succeeding Renewal Term or Landlord exercises its right to terminate this agreement pursuant to Paragraph 10 herein.

AA

4. **RENT.**

(a) Within fifteen (15) business days following the Term Commencement Date and on the first day of each month thereafter. Tenant shall pay to Landlord as rent Twelve Hundred and 00/100 Dollars (\$1,200.00) per month ("Rent"). Rent for any fractional month at the beginning or at the end of the Term or Renewal Term shall be prorated. Rent shall be payable to Landlord at 100 Third Street, Castle Rock, Colorado, 80104; Attention: County Administrator. All of Tenant's monetary obligations set forth in this Agreement are conditioned upon Tenant's receipt of an accurate and executed W-9 Form from Landlord.

(b) Rent shall increase on each anniversary of the Term Commencement Date by an amount equal to four percent (4%) of the Rent than in effect for the previous year.

5. **USES.**

From and after the Term Commencement Date, the Premises may be used by Tenant for any lawful activity in connection with the provision of communications services, and Tenant shall have the ongoing right to perform such Investigations and Tests as Tenant may deem necessary or desirable. Landlord agrees to cooperate with Tenant, at Tenant's expense, in making application for and obtaining all licenses, permits and any and all other necessary approvals that may be required for Tenant's intended use of the Premises.

6. **FACILITIES; UTILITIES; ACCESS.**

(a) Tenant has the right to construct, erect, maintain, test, replace, remove, operate and upgrade on the Premises communications facilities, including without limitation utility lines, transmission lines, an air conditioned equipment shelter(s), electronic equipment, transmitting and receiving antennas, a standby power generator, and supporting equipment and structures therefore ("Tenant Facilities"). In connection therewith, Tenant has the right to do all work necessary to prepare, maintain and alter the Premises for Tenant's business operations and to install transmission lines connecting the antennas to the transmitters and receivers. All of Tenant's construction and installation work shall be performed at the Tenant's sole cost and expense and in a good and workmanlike manner. Tenant acknowledges that the primary use of the Property is a park provided for the use and enjoyment of the citizens of Douglas County, and Tenant agrees that all work performed in connection with the construction, installation, alteration, operation and maintenance of Tenant Facilities shall be performed in a manner that shall not interfere with the primary use of the Property. In connection therewith, Tenant agrees to submit a construction schedule to Landlord prior to performing any construction, installations or alteration work on the Property, and the parties shall cooperate to perform such construction, installation and alteration work in a manner that minimizes the affects on the Property. Tenant shall hold title to the Tenant Facilities and all of the Tenants Facilities shall remain Tenant's personal property and are not fixtures. Tenant has the right to remove the Tenant Facilities at its sole expense on or before the expiration or earlier termination of this Agreement, and Tenant shall repair any damage to the Premises caused by such removal. Upon the expiration or earlier termination of this Agreement, Tenant shall remove the Tenant Facilities from the Property and shall restore the property to substantially the same condition as received, normal wear and tear excepted.

(b) Tenant shall pay for the electricity it consumes in its operations at the rate charged by the servicing utility company. Tenant shall ensure that the facilities are separately metered. Landlord agrees to sign such documents or easements as may be required by said utility companies to provide such service to the Premises, including the grant to Tenant or to the servicing utility company at no cost to the Tenant, of an easement in, over, across or through the Land as required by such servicing utility company to provide utility services as provided herein. Any easement necessary for such power or other utilities will be at a location acceptable to the Landlord and the servicing company.

(c) Tenant, Tenant's employees, agents and contractors shall have access to the Premises without notice to Landlord twenty-four (24) hours a day, seven (7) days a week, at no charge. Landlord grants to Tenant, and Tenant's agents, employees and contractors a non-exclusive right and easement for pedestrian and vehicular ingress and egress across that portion of the Land described in Exhibit B to the extent that such use does not interfere with the primary use of the property.

(d) Landlord shall maintain all access roadways from the nearest public roadway to the Premises in a manner sufficient to allow pedestrian and vehicular access at all times under normal weather conditions. Landlord shall be responsible for maintaining and repairing such roadway, at its sole expense, except for any damage caused by Tenant's use of such roadways.

(e) Tenant shall remove and replace a light pole with a said light pole that shall be manufactured and with sufficient structural capability to accommodate said light pole apparatus and Tenant's wireless communication facility in accordance with the plans and specifications approved by Landlord, and attached hereto as Exhibit B. Upon completion of construction, the Tower will become part of the Land, and title to the Tower shall vest with the Landlord. Landlord shall be responsible for the maintenance of the Tower. Landlord shall provide sufficient space to Tenant on the Tower for Tenant's antennas and associated equipment. The foregoing notwithstanding, should Landlord require access for the operation and maintenance of the Tower, Tenant shall, upon notice from Landlord, work with Landlord to facilitate such operation and maintenance. Neither Landlord or any of Landlord's agents, employees, invitees, contractors or other tenants may come into physical contact with any of the equipment, antennas or other personal property of the Tenant Facilities.

7. **INTERFERENCE.**

(a) Tenant shall operate the Tenant Facilities in compliance with all Federal Communications Commission ("FCC") requirements and in a manner that will not cause interference to Landlord or other lessees or licensees of the Property, provided that any such installations predate that of the Tenant Facilities. Tenant is aware that Quest Wireless LCC maintains a communications facility on the sites.

(b) Subsequent to the installation of the Tenant Facilities, Landlord will not, and will not permit its lessees or licensees to, install new equipment on or make any alterations to the Property or property contiguous thereto owned or controlled by Landlord, if such modifications are likely to cause interference with Tenant's operations. In the event interference occurs, Landlord agrees to use a good faith effort to eliminate such interference, in a reasonable time period. Moreover, in the event that a third party telecommunications carrier or tower management company ("Other Telecommunications Tenant") desires to use the Property in a manner which may interfere with Tenant's operations, Landlord shall endeavor to cause such other Telecommunications Tenant to provide it with a copy of the plans and specifications for the Other Telecommunications Tenant's proposed improvements ("improvements"). Tenant shall reasonably cooperate with Landlord, in determining whether the improvements will interfere with Tenant's operations. Tenant will notify Landlord within fourteen (14) calendar days of either (i) Tenant's approval of the improvements; or (ii) requests for changes or modifications to the plans and specifications, including any technical measures required to eliminate such potential interference. Tenant's approval of the improvements shall not be unreasonably withheld or delayed, but may be conditioned upon the implementation of specific measures by such third party tenant to assure that interference does not occur as a result of their improvements. Landlord's failure to comply with this paragraph shall be a material breach of this Agreement.

8. **TAXES.**

If personal property taxes are assessed, Tenant shall pay any portion of such taxes directly attributable to the Tenant Facilities. Tenant acknowledges that the property is currently exempt from the assessment of real property taxes. However, if in the future any increase to the Landlord's real property taxes is the direct result of Tenant's improvements on the Premises, the Tenant shall reimburse the Landlord that proportionate share of such tax increase provided that as a condition of Tenant's obligation to pay such taxes increase, Landlord provides to Tenant the documentation from the taxing authority reasonably acceptable to Tenant, indicating that the increase is due to Tenant's improvements. Nothing in this paragraph shall be construed as limiting either party's right to contest, appeal or challenge any tax assessment.

9. **WAIVER OF LANDLORD'S LIEN.**

Landlord waives any lien rights it may have concerning the Tenant Facilities which are deemed Tenant's personal property and not fixtures, and Tenant has the right to remove the same at any time without Landlord's consent.

10. **TERMINATION.** This agreement may be terminated as follows:

(a) By Lessor if Lessee fails to cure a default payment of amounts due hereunder within thirty (30) days after Lessee's receipt of written notice from Lessor;

(b) by the non-defaulting party if the other party defaults (other than a default described under Section 10(a) above) and fails to cure such default within sixty (60) days after written notice of such default is received by the defaulting party; provided, however, that if such default is capable of being cured, the Lease may not be terminated so long as the defaulting party commences appropriate curative action within such sixty (60) day period and thereafter diligently prosecutes such cure to completion as promptly as possible; and

(c) by Lessee upon thirty (30) days prior to written notice to Lessor.

11. **DESTRUCTION OR CONDEMNATION.**

If the Premises or Tenant Facilities are damaged, destroyed, condemned or transferred in lieu of condemnation, Tenant may elect to terminate this Agreement as of the date of the damage, destruction, condemnation or transfer in lieu of condemnation by giving notice to Landlord no more than forty-five (45) days following the date of such damages, destruction, condemnation or transfer in lieu of condemnation. If Tenant chooses not to terminate this Agreement, Rent shall be reduced or abated in proportion to the actual reduction or abatement of use of the Premises.

12. **INSURANCE.**

Tenant, at Tenant's sole cost and expense, shall produce and maintain on the Premises and on the Tenant Facilities, bodily injury and property damage insurance with a combined single limit of at least One Million and 00/100 Dollars (\$1,000,000.00) per occurrence. Such insurance shall insure, on an occurrence basis, against all liability of Tenant, its employees and agents arising out of or in connection with Tenant's use of the Premises, all as provided for herein. Landlord, at Landlord's sole cost and expense, shall procure and maintain on the Property, bodily injury and property damage insurance with a combined single limit of at least One Million and 00/100 Dollars (\$1,000,000.00) per occurrence. Such insurance shall insure, on an occurrence basis, against all liability of Landlord, its employees and agents arising out of or in connection with Landlord's use, occupancy and maintenance of the Property. Owner shall be named as an additional insured on Tenant's insurance policy. Each party shall provide to the other a certificate of insurance evidencing the coverage required by this paragraph within thirty (30) days following the Effective Date.

13. **WAIVER OF SUBROGATION.**

Landlord and Tenant release each other and their respective participants, employees, representatives and agents, from any claims for damage to any person or to the Property or the Premises or to the Tenant Facilities or any other property thereon caused by, or that result from, risks insured against under any insurance policies carried by the parties and in force at the time of any such damages. Landlord and Tenant shall cause each insurance policy obtained by them to provide that the insurance company waives all right of recovery by way of subrogation against the other in connection with any damage covered by any policy. Neither Landlord nor Tenant shall be liable to the other for any damage caused by fire or any of the risks insured against under any insurance policy required by Paragraph 12.

14. **LIABILITY AND INDEMNITY.**

Tenant shall indemnify, save harmless and defend Landlord against any and all damages to property or injuries or death of any person or persons, including, without limitation, property and employees or agents of Landlord, and shall defend, indemnify and save harmless Landlord from any and all claims, damages, demands, suits, actions or proceedings, including without limitation, workers' compensation claims or actions brought for violation of this Lease, in any way resulting from or arising out of Tenant's use of the Premises and acts or omissions of employees, agents, or subcontractors of Tenant; provided, however, that Tenant need not indemnify or save harmless Landlord, its officers, agents and employees from damages resulting from the gross negligence or willful misconduct of Landlord's officers, agents and employees. Notwithstanding the foregoing, Tenant acknowledges that nothing herein shall be deemed a waiver of Landlord's rights pursuant to any federal, state or local law, including but not limited to the Colorado Government Immunity Act (CRS 24-1-101, et seq.). In the event of Termination or uncured default, Landlord's liability should be limited to the amount currently owned by Tenant.

15. **ASSIGNMENT AND SUBLETTING**

Tenant may not assign, or otherwise transfer all or any part of its interest in this Agreement or in the Premises without prior consent of Landlord; provided, however, that Tenant may assign its interest to its parent company, any subsidiary or affiliate of its parent company or to any successor-in-interest or entity acquiring fifty-one percent (51%) or more of its stock or assets. Landlord may assign this Agreement, which may be evidenced by written notice to Tenant within a reasonable period of time thereafter, provided that the assignee assumes all of Landlord's obligations herein, including but not limited to, those set forth in Paragraph 9 ("Waiver of Landlord's Lien") above. This Agreement shall run with the Property and shall be binding upon and inure to the benefit of the parties, their responsible successors, personal representatives, heirs and assigns.

16. **WARRANTY OF TITLE AND QUIET ENJOYMENT**

Landlord warrants that: (i) Landlord owns the Property in fee simple and has rights of access thereto and the Property is free and clear of all liens, encumbrances and restrictions except those of record as of the Effective Date; and (ii) Landlord covenants and agrees with Tenant that Tenant may peacefully and quietly enjoy the Premises for the purposes set forth herein, provided that Tenant is not in default hereunder after notice and expiration of all cure periods. Tenant acknowledges that the primary purpose of the underlying real property is to serve as a park and recreational area to citizens of Douglas County.

17. **REPAIRS**

Tenant shall repair any damage to the Premises or Property caused by the negligence or willful misconduct of the Tenant. Upon expiration or termination thereof, Tenant shall repair the Premises to substantially the condition in which it existed upon start of construction, reasonable wear and tear and loss by casualty or other causes beyond Tenant's control excepted.

18. **HAZARDOUS MATERIAL**

(a) As of the Effective Date of this Agreement: (1) Tenant hereby represents and warrants that it shall not use, generate, handle, store or dispose of any Hazardous Material in, on, under, upon or affecting the Property in violation of any Environmental Law (as defined below), and (2) Landlord hereby represents and warrants that (i) it has no knowledge of the presence of any Hazardous Material located in, on, under, upon or affecting the Property in violation of any Environmental Law; (ii) no notice has been revealed by or on behalf of Landlord from, and Landlord has no knowledge that notice has been given to any predecessor owner or operator of the Property by, any governmental entity or any person or entity claiming any violation of, or requiring compliance with any Environmental Law for any environmental damage in, on, under, upon or affecting the Property; and (iii) Landlord will not permit itself or any third party to use, generate, handle, store or dispose of any Hazardous Material in, on, under, upon or affecting the Property in violation of any Environmental Law.

(b) "*Hazardous Material*" means any solid, gaseous or liquid wastes (including hazardous wastes), regulated substances, pollutants, or contaminants or terms of similar import, as such terms are defined in any Environmental Law, and shall include, without limitation, any petroleum or petroleum products or by-products, flammable explosives, radioactive materials, asbestos in any form, polychlorinated biphenyls and any other substance or material which constitutes a threat to health, safety, property or the environment or which has been or is in the future determined by any governmental entity to be prohibited, limited or regulated by any Environmental Law.

(c) "*Environmental Law*" means any and all federal, state or local laws, rules, regulations, codes, ordinances, or by-laws, and any judicial or administrative interpretations thereof, including orders, decrees, judgments, ruling, directives or notices of violation, that create duties, obligations or liabilities with respect to: (i) human health; or (ii) environmental pollution, impairment or disruption, including, without limitation, laws governing the existence, use, storage, treatment, discharge, release, containment, transportation, generation, manufacture, refinement, handling, production, disposal, or management of any Hazardous Material, or otherwise regulating or providing for the protection of the environment.



19. **MISCELLANEOUS.**

(a) This Agreement constitutes the entire agreement and understanding between the parties, and supersedes all offers, negotiations and other agreements concerning the subject matter contained herein. Any amendments to this Agreement must be in writing and executed by both parties.

(b) Both parties represent and warrant that their use of the Property and their personal property located herein is in compliance with all applicable, valid and enforceable statutes, laws, ordinances and regulations of any competent government authority.

(c) If any provision of this Agreement is invalid or unenforceable with respect to any party, the remainder of this Agreement or the application of such provision to persons other than those as to whom it is held invalid or unenforceable, shall not be affected and each provision of this Agreement shall be valid and enforceable to the fullest extent permitted by law. 

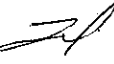
(d) This Agreement shall be binding on and inure to the benefit of the successors and permitted assignees of the respective parties.

(e) Any notice or demand required to be given herein shall be made by certified or  registered mail, return receipt requested, or reliable overnight courier to the address of the respective parties set forth below: 

Landlord:

Douglas County

Attn: County Administrator

Board of County Commissioners

100 Third Street, Castle Rock, CO 80104

Tenant:

Cingular Wireless LLC

Attn: Network Real Estate Administration

RE: Cingular Wireless Cell Site #: 1431: Cell Site Name: Lincoln & Jordan

6100 Atlantic Boulevard, Norcross, Georgia 30071

With a copy to:

Cingular Wireless LLC

Attn: Legal Department

RE: Cingular Wireless Cell Site #: 1431: Cell Site Name: Lincoln & Jordan

15 East Midland Avenue, Paramus, NJ 07652

Landlord or Tenant may from time to time designate any other address for this purpose by written notice to the other party. All notices hereunder shall be deemed received upon actual receipt.

(f) This Agreement shall be governed by the laws of the State of Colorado.

(g) Landlord agrees to execute and deliver to Tenant a Memorandum of this Agreement in the form annexed hereto as Exhibit C and acknowledges that such Memorandum of Agreement will be recorded by Tenant in the official records of the county where the Property is located.

(h) In the even the Property is encumbered by a mortgage or deed of trust, Landlord agrees to obtain and deliver to Tenant an executed non-disturbance and attornment instrument for each such mortgage or deed of trust in a form reasonably acceptable to both parties.

(i) Landlord agrees to fully cooperate, including executing necessary documentation, with Tenant to obtain information and documentation clearing any outstanding title issues that could adversely affect Tenant's interest in the Premises created by this Agreement.

(j) In any case where the approval or consent of one party hereto is required, requested or otherwise to be given under this Agreement, such party shall not unreasonably delay or withhold its approval or consent.

(k) Each of the parties hereto represent and warrant that they have the right, power, legal capacity and authority to enter into and perform their respective obligations under this Agreement.

(l) The captions and headings in this Agreement are for convenience only and in no way define, limit or describe the scope or intent of any provision of this Agreement.

(m) All Riders and Exhibits annexed hereto form material parts of this Agreement.

(n) This Agreement may be executed in duplicate counterparts, each of which shall be deemed an original.

20.

MARKETING AND LIGHTING REQUIREMENTS.

Landlord shall be responsible for compliance with all marketing and lighting requirements of the Federal Aviation Administration ("FAA") and the FCC. Should Tenant be cited because the Property is not in compliance and should Landlord fail to cure the conditions of noncompliance, Tenant may either Terminate this Agreement or proceed to cure the conditions of noncompliance at Landlord's expense, which amounts may be deducted from the Rent.

SIGNATURES ON FOLLOWING PAGE

In WITNESS WHEREOF, the parties have executed this Agreement as of the date first written above:

Landlord:
Board of County Commissioners
Douglas County
State of Colorado

By: Melanie A. Worley
Melanie A. Worley, Chair

Tenant:
New Cingular Wireless PCS,
LLC, a Delaware limited liability
company

By: Dennis Neal

Name: Dennis Neal
Title: Real Estate and
Construction Manager

Date: 2/6/06

Date: 02/21/06

Attest:
Mary
Deputy County Clerk

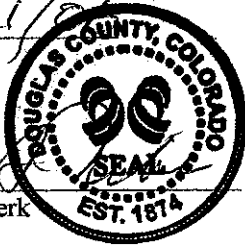

Approved as to Content:

DJB
Douglas J. DeBord, County Administrator

Approved as to Fiscal Content:

Karen Montgomery
Karen Montgomery, Finance Director

Approved as to Form:

Lance Ingalls
Lance Ingalls, County Attorney

Insurance Provisions Approved:

Sherry Monroe
Sherry Monroe, Risk Manager

LLC ACKNOWLEDGMENT

STATE OF Colorado)
) ss:
COUNTY OF Adams)

I CERTIFY that on February 6 2006, **Dennis Neal** [name of representative] personally came before me and acknowledged under oath that he or she:

(a) is the Real Estate and Construction Manager [title] of New Cingular Wireless Services of Colorado PCS, LLC a Delaware limited liability company [name of LLC], the LLC named in the attached instrument,

(b) was authorized to execute this instrument on behalf of the corporation and

(c) executed the instrument as the act of the corporation.

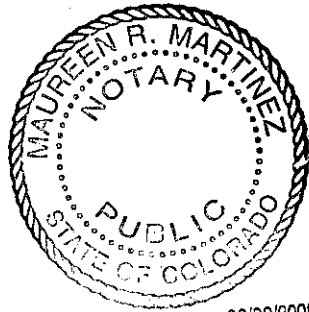

My Commission Expires 03/20/2009

Notary Public: Maureen R Martinez

My Commission Expires: 3/20/09

EXHIBIT A
Page 1 of 2
Lincoln & Jordan # 1431

To the Agreement dated January 21, 2006, by and between Douglas County, State of Colorado, as Landlord and New Cingular Wireless Services PCS, LLC, a Delaware Limited Liability Company, as Tenant.

Landlord owns certain property with an address of Lincoln Avenue and Challenger Drive, Parker, CO 80134 herein identified as the "Property".

Tenant lease approximately 300 square feet of land of the Property identified as the "Premises". The Premises described and depicted as follows:

Parcel Numbers 2233-093-00-004 and 2233-162-00-012, County of Douglas, State of Colorado.

Site Diagram on Following Page

Site Diagram Not to Scale

County: Douglas

APN: 2233-093-00-004 and 2233-162-00-012

Address: Lincoln Avenue and Challenger Drive, Parker, CO 80134

Lease area: approximately 300 square feet

Landlord Initial:



Tenant Initial:



EXHIBIT A
DESCRIPTION OF PREMISES
 Page 2 of 2

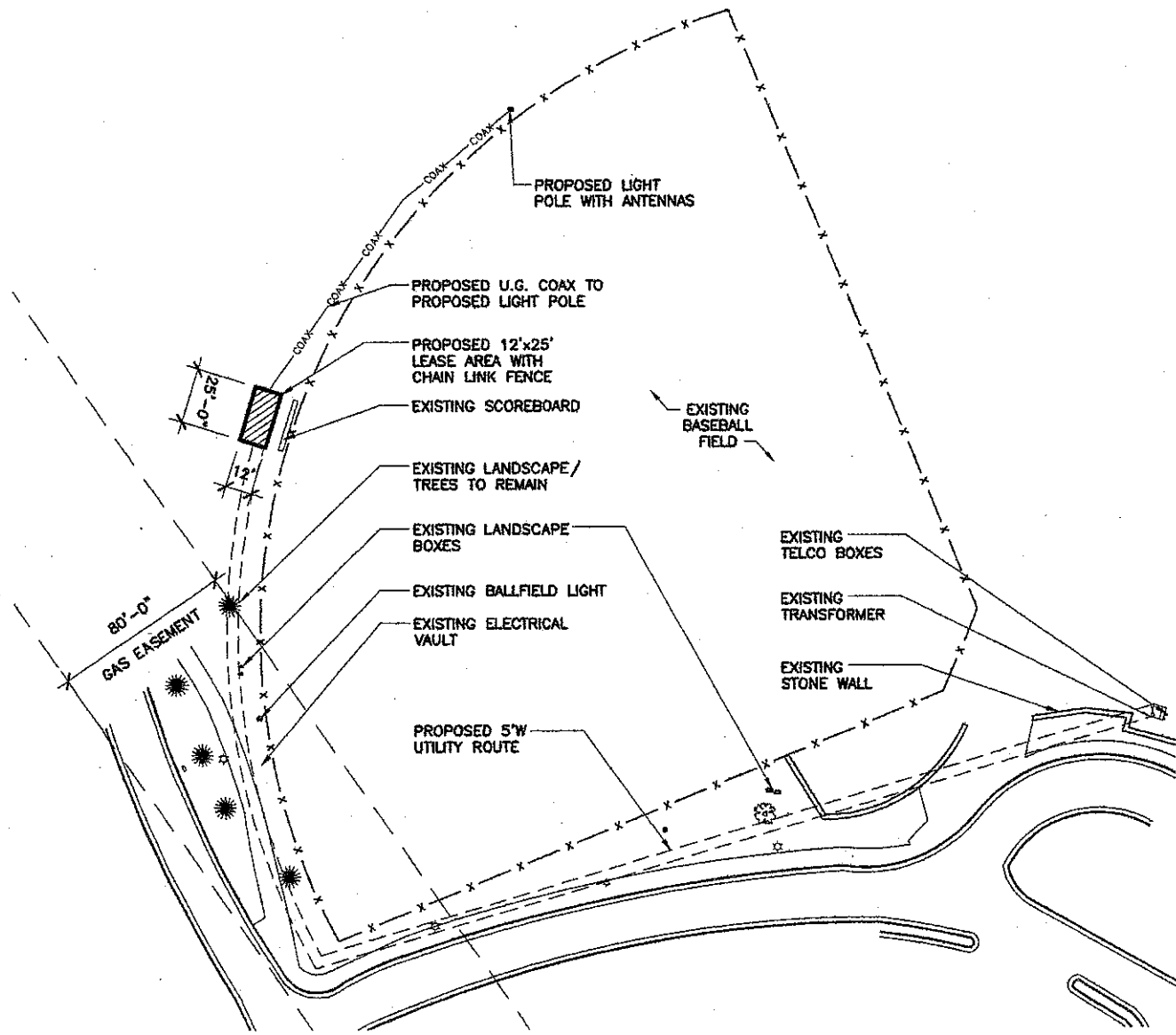

SITE DIAGRAM 
 NOT TO SCALE

Market: Rocky Mountain Region
Cell Site Number: COU1431
Cell Site Name: Lincoln & Jordan
Fixed Asset Number: 10099211
Reference Number of
Prior Recorded Documents: _____

FIRST AMENDMENT TO COMMUNICATIONS SITE LEASE AGREEMENT

THIS FIRST AMENDMENT TO COMMUNICATIONS SITE LEASE AGREEMENT ("**Amendment**"), dated as of the latter of the signature dates below ("**Effective Date**"), is by and between Douglas County, Board of Commissioners, having a mailing address of 100 Third Street, Castle Rock, Colorado 80104 ("**Landlord**") and New Cingular Wireless PCS, LLC, a Delaware limited liability company, having a mailing address of 12555 Cingular Way, Suite 1300, Alpharetta, GA 30004 ("**Tenant**").

WHEREAS, Landlord and Tenant entered into a Communications Site Lease Agreement dated February 21, 2006, whereby Landlord leased to Tenant certain Premises, therein described, that are a portion of the property located at 17305 East Lincoln Avenue, Parker Colorado 80134 ("**Agreement**"); and

WHEREAS, Landlord and Tenant desire to amend the Agreement to (i) increase the leased space (ii) allow Tenant to replace the existing light pole tower, (iii) grant Tenant an additional five-foot wide utility right-of-way, and (iv) increase monthly rent.

NOW THEREFORE, in consideration of the foregoing and other good and valuable consideration, the receipt and sufficiency of which are hereby acknowledged, Landlord and Tenant agree as follows:

- 1. Premises.** Upon full execution of this Amendment, Landlord hereby grants Tenant (i) an additional 180 square feet of lease space for a total leased Premises of 480 square feet, (ii) the right to increase on the existing 80' light pole tower an additional 2' in height on the 20'x26" antenna canister, and (iii) an additional five-foot wide utility right-of-way extending from the nearest public right of way, Lincoln Avenue, to the Premises. Tenant's proposed modifications to the Premises are more particularly described on the attached Exhibit B-1. The attached Exhibit B-1 shall supersede and replace Exhibit B of the Agreement.
- 2. Rent Increase.** Commencing upon the first of the month following full execution of this Amendment, Rent shall increase by an additional Three Hundred Dollars (\$300.00) per month.
- 3. Notices.** Tenant's addresses for notice purposes is amended in Section 19(e) as follows:
If to Tenant:

New Cingular Wireless PCS, LLC
Attn: Network Real Estate Administration
Re: Cell Site #: COU1431; Cell Site Name: Lincoln and Jordan (CO)
Fixed Asset No: 10099211
12555 Cingular Way, Suite 1300
Alpharetta, GA 30004

With a required copy of such notice sent to AT&T Legal at:
New Cingular Wireless PCS, LLC
Attn: AT&T Legal Department
Re: Cell Site #: COU1431; Cell Site Name: Lincoln and Jordan (CO)

12-2010 Amendment

Fixed Asset No: 10099211

If sent via certified or registered mail:
PO Box 97061
Redmond, WA 98073-9761

Or if sent via nationally recognized overnight courier:
16331 NE 72nd Way
Redmond, WA 98052-7827

A copy sent to the Legal Department is an administrative step which alone does not constitute legal notice. Either party hereto may change the place for the giving of notice to it by thirty (30) days' prior written notice to the other.

- 4. **Memorandum of Lease.** Either party will, at any time upon fifteen (15) days prior written notice from the other, execute, acknowledge and deliver to the other a recordable Memorandum of Lease substantially in the form of the Attachment 1. Either party may record this memorandum at any time, in its absolute discretion.
- 5. **Other Terms and Conditions Remain.** In the event of any inconsistencies between the Agreement and this Amendment, the terms of this Amendment shall control. Except as expressly set forth in this Amendment, the Agreement otherwise is unmodified and remains in full force and effect. Each reference in the Agreement to itself shall be deemed also to refer to this Amendment.
- 6. **Capitalized Terms.** All capitalized terms used but not defined herein shall have the same meanings as defined in the Agreement.

IN WITNESS WHEREOF, the parties have caused this Agreement to be effective as of the last date written below.

LANDLORD:
Douglas County, Board of County Commissioners

TENANT:
New Cingular Wireless PCS, LLC,
a Delaware limited liability company

By: AT&T Mobility Corporation
Its: Manager

By: _____
Print Name:
Its: Chair
Date:

By: _____
Print Name: Dennis Neal
Its: Real Estate and Construction Manager
Date:

Attest:

Deputy County Clerk

Approved as to Content:

12-2010 Amendment

County Administrator

Approved as to Fiscal Content:

Finance Director

Approved as to Form:

County Attorney

Insurance Provisions Approved:

Risk Manager

12-2010 Amendment

EXHIBIT B-1

DESCRIPTION OF PREMISES

Page 1 of 2

To the First Amendment to the Communications Site Lease Agreement dated _____, 2012, by and between Douglas County, State of Colorado, as Landlord, and New Cingular Wireless PCS, LLC, a Delaware Limited Liability Company, as Tenant.

The Premises are described and/or depicted as follows:

Landlord owns certain property with an address of Lincoln Avenue and Challenger Drive, Parker Colorado 80134 herein identified as the "Property".

Property Legal Description:

Tenant leases approximately 375 square feet of land of the Property identified as the "Premises".
The Premises described and depicted as follows:

Parcel Numbers 2233-093-00-0004
2233-162-00-0121
2233-162-00-014
2233-162-00-013
2233-162-00-025

County of Douglas, State of Colorado.

County: Douglas

Address: Lincoln Avenue and Challenger Drive, Parker, Colorado 800134

Lease Area Sketch or Survey: On Following Page

Landlord Initial _____

Tenant Initial _____

Notes:

1. This Exhibit may be replaced by a land survey and/or construction drawings of the Premises once received by Tenant.
2. Any setback of the Premises from the Property's boundaries shall be the distance required by the applicable governmental authorities.
3. Width of access road shall be the width required by the applicable governmental authorities, including police and fire departments.
4. The type, number and mounting positions and locations of antennas and transmission lines are illustrative only. Actual types, numbers and mounting positions may vary from what is shown above.

12-2010 Amendment

ATTACHMENT 1
(For drafting purposes only)

Prepared by, and after recording

Return to:

New Cingular Wireless PCS, LLC
12555 Cingular Way, Suite 1300
Alpharetta GA 30004
Attn: Network Real Estate Administration

Grantor:	Douglas County, Board of Commissioners		
Grantee:	New Cingular Wireless PCS, LLC, a Delaware limited liability company		
Legal Description:	Official legal description attached as <u>Exhibit 1</u>		
Tax Serial No.:	2233-093-00-0004, 2233-162-00-0121, 2233-162-00-014, 2233-162-00-013, 2233-162-00-025		
Cell Site Name & #:	Lincoln and Jordan	Fixed Asset #:	10099211
State:	Colorado	County:	Douglas

MEMORANDUM OF FIRST, AMENDMENT TO LEASE

This Memorandum of First, Amendment to Lease is entered into on this ____ day of _____, 2012, by and between Douglas County, Board of Commissioners, having a mailing address of 100 Third Street, Castle Rock, Colorado 80104 ("**Landlord**") and New Cingular Wireless PCS, LLC, a Delaware limited liability company, having a mailing address of 12555 Cingular Way, Suite 1300, Alpharetta, GA 30004 ("**Tenant**").

1. Landlord and Tenant entered into a certain Communications Site Lease Agreement ("**Agreement**") on the 21st day of February, 2006, as amended by that certain First Amendment to Communication Site Lease Agreement dated _____, 2012, for the purpose of installing, operating and maintaining a communications facility and other improvements.
2. The initial lease term of five (5) years ("**Initial Term**") commenced May 19, 2006, with three (3) successive five (5) year options to renew.
3. The portion of the land being leased to Tenant (the "**Premises**") is described in **Exhibit 1** annexed hereto.
4. This First Amendment to Memorandum of Lease is not intended to amend or modify, and shall not be deemed or construed as amending or modifying, any of the terms, conditions or provisions of the Agreement, all of which are hereby ratified and affirmed. In the event of a conflict between the provisions of this First Amendment to Memorandum of Lease and the provisions of the Agreement, the provisions of the Agreement shall control. The Agreement shall be binding upon and inure to the benefit of the parties and their respective heirs, successors, and assigns, subject to the provisions of the Agreement.

12-2010 Amendment

IN WITNESS WHEREOF, the parties have executed this Memorandum of First Amendment to Lease as of the day and year first above written.

LANDLORD:

Board of County Commissioners
Douglas County
State of Colorado,

TENANT:

New Cingular Wireless PCS, LLC,
a Delaware limited liability company

By: AT&T Mobility Corporation
Its: Manager

By: _____
Print Name:
Its: Chair
Date:

By: _____
Print Name: Dennis Neal
Its: Real Estate and Construction Manager
Date:

Attest:

Deputy County Clerk

Approved as to Content:

County Administrator

Approved as to Fiscal Content:

Finance Director

Approved as to Form:

County Attorney

Insurance Provisions Approved:

Risk Manager

Prepared by:

SAC NAME Stacey L. Bell-Brower

SAC FIRM Black & Veatch Corp.

FIRM ADDRESS 6300 South Syracuse Way, Suite 300

CITY, STATE ZIP Centennial, Colorado 80111

EXHIBIT 1

DESCRIPTION OF PREMISES

Page ____ of ____

to the Memorandum of First Amendment to Lease dated _____, 2012, by and between Douglas County Board of Commissioners, as Landlord, and New Cingular Wireless PCS, LLC, a Delaware limited liability company, as Tenant.

The Premises are described and/or depicted as follows:

Property Legal Description:

TITLE REPORT
PREPARED BY: LAND TITLE GUARANTEE COMPANY
ORDER NUMBER: ACT70318097
EFFECTIVE DATE: 12-08-2011

LEGAL DESCRIPTION:
PARCEL A:

A PARCEL OF LAND LOCATED IN THE SOUTH HALF OF SECTION 9, TOWNSHIP 6 SOUTH, RANGE 66 WEST OF THE SIXTH PRINCIPAL MERIDIAN, DOUGLAS COUNTY, STATE OF COLORADO, MORE PARTICULARLY DESCRIBED AS FOLLOWS:
COMMENCING AT THE SOUTHWEST CORNER OF SAID SECTION 9;
THENCE N87°53'37"E ALONG THE SOUTH LINE OF THE SOUTHWEST ONE-QUARTER OF SAID SECTION 9, A DISTANCE OF 1541.29 FEET TO THE POINT OF BEGINNING ON A NON-TANGENT CURVE WHENCE THE CENTER OF SAID CURVE BEARS S47°43'45"E;
THENCE ALONG THE ARC OF SAID NON-TANGENT CURVE TO THE RIGHT, HAVING A CENTRAL ANGLE OF 25°07'22" AND A RADIUS OF 600.00 FEET, A DISTANCE OF 263.08 FEET TO THE POINT OF TANGENT;
THENCE N67°23'37"E ALONG SAID TANGENT A DISTANCE OF 345.20 FEET TO A POINT OF CURVE;
THENCE ALONG THE ARC OF SAID CURVE TO THE RIGHT, HAVING A CENTRAL ANGLE OF 65°00'00" AND A RADIUS OF 600.00 FEET, A DISTANCE OF 680.68 FEET TO THE POINT OF TANGENT;
THENCE S47°36'23"E ALONG SAID TANGENT A DISTANCE OF 184.70 FEET TO A POINT ON THE SOUTH LINE OF THE SOUTHEAST ONE-QUARTER OF SAID SECTION 9;
THENCE S87°58'03"W CONTINUING ALONG SAID SOUTH LINE A DISTANCE OF 185.77 FEET TO THE SOUTHEAST CORNER OF THE SOUTHWEST ONE-QUARTER OF SAID SECTION 9;
THENCE S87°53'37"W ALONG THE SOUTH LINE OF THE SOUTHWEST ONE-QUARTER A DISTANCE OF 1118.70 FEET TO THE POINT OF BEGINNING.

EXCEPTING THEREFROM THAT PORTION CONVEYED TO THE TOWN OF PARKER BY QUIT CLAIM DEED RECORDED JANUARY 12, 2006 UNDER RECEPTION NO. 2006003346.

LEGAL DESCRIPTION:
PARCEL B:

IMPRC

A PARCEL OF LAND LOCATED IN SECTION 16, TOWNSHIP 6 SOUTH, RANGE 66 WEST OF THE SIXTH PRINCIPAL MERIDIAN, COUNTY OF DOUGLAS, STATE OF COLORADO, BEING DESCRIBED AS FOLLOWS:

COMMENCING AT THE NORTH QUARTER CORNER OF SAID SECTION 16, SAID POINT BEING THE POINT OF BEGINNING; THENCE NORTH 87 DEGREES 58 MINUTES 13 SECONDS EAST A DISTANCE OF 722.26 FEET ALONG THE NORTH LINE OF THE NORTHEAST QUARTER OF SAID SECTION 16; THENCE SOUTH 21 DEGREES 54 MINUTES 24 SECONDS WEST A DISTANCE OF 819.77 FEET TO A POINT ON THE NORTH RIGHT-OF-WAY LINE OF LINCOLN AVENUE AS RECORDED NOVEMBER 29, 1977 IN DOUGLAS COUNTY RECORDS IN BOOK 319 AT PAGE 174 AND RECORDED OCTOBER 17, 1978 IN BOOK 344 AT PAGE 425; THENCE WESTERLY ALONG THE NORTH RIGHT-OF-WAY LINE OF LINCOLN AVENUE THE FOLLOWING THREE COURSES:

- 1. SOUTH 73 DEGREES 22 MINUTES 07 SECONDS WEST A DISTANCE OF 52.41 FEET TO A POINT OF CURVE;
2. ALONG THE ARC OF A CURVE TO THE RIGHT HAVING A DELTA OF 18 DEGREES 03 MINUTES 29 SECONDS, A RADIUS OF 2467.25 FEET, A DISTANCE OF 777.61 FEET TO A POINT OF TANGENT;
3. NORTH 88 DEGREES 34 MINUTES 24 SECONDS WEST A DISTANCE OF 83.76 FEET TO A POINT ON THE EASTERLY LINE OF A GAS EASEMENT RECORDED DECEMBER 4, 1967 IN DOUGLAS COUNTY RECORDS IN BOOK 180 AT PAGE 332 AND 333;

THENCE NORTH 34 DEGREES 35 MINUTES 34 SECONDS WEST A DISTANCE OF 986.37 FEET ALONG SAID EASTERLY LINE TO A POINT ON THE NORTH LINE OF THE NORTHWEST QUARTER OF SAID SECTION 16; THENCE NORTH 87 DEGREES 53 MINUTES 55 SECONDS EAST A DISTANCE OF 1046.29 FEET ALONG SAID NORTH LINE TO THE POINT OF BEGINNING.

EXCEPTING THEREFROM THAT PORTION CONVEYED TO THE TOWN OF PARKER BY THE DEED RECORDED APRIL 27, 1993 IN BOOK 1121 AT PAGE 1399.

AND EXCEPTING THEREFROM THAT PORTION CONVEYED TO THE TOWN OF PARKER BY THE DEED RECORDED JANUARY 12, 2006 UNDER RECEPTION NO. 2006003346.

Lease Area Sketch or Survey:

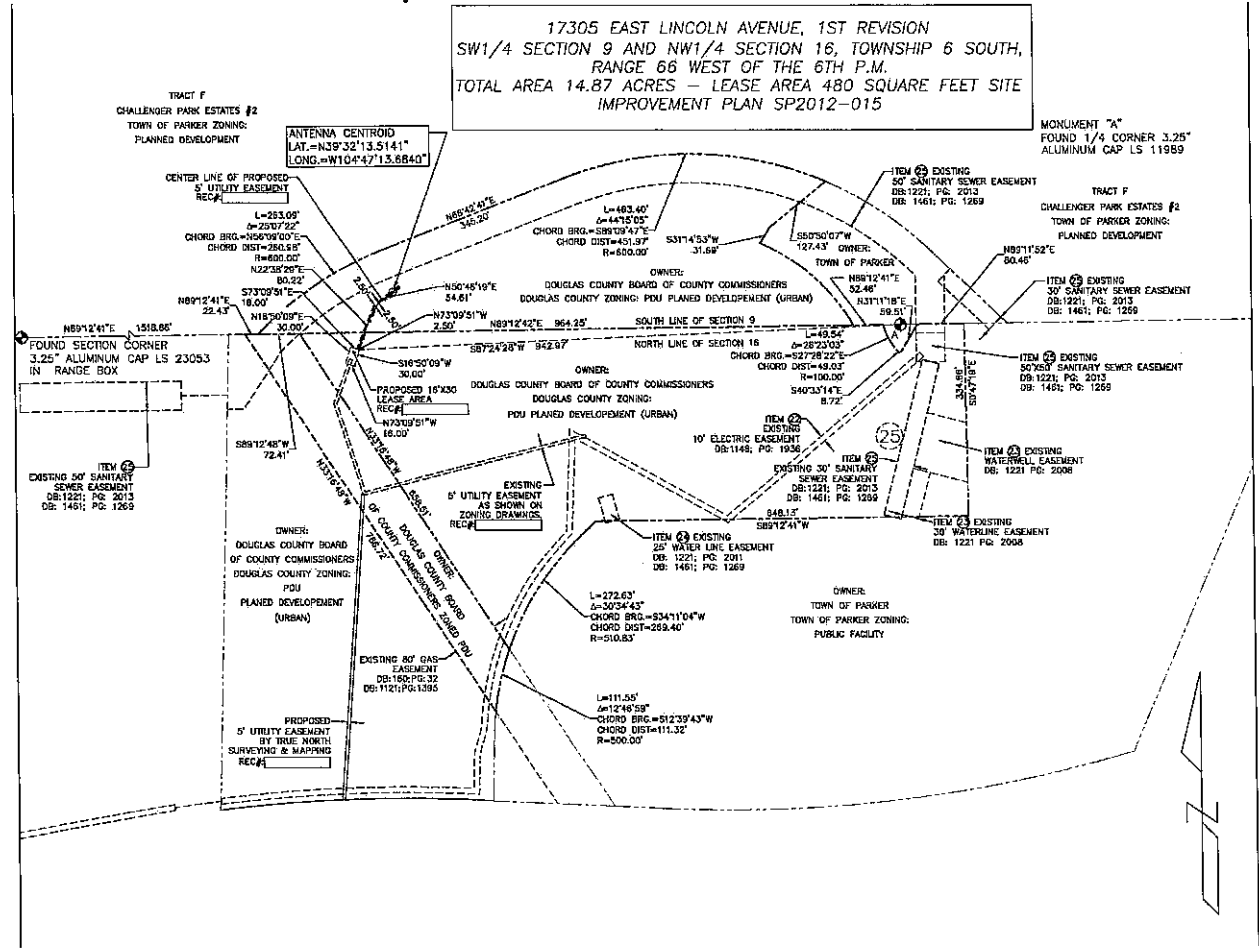

17305 EAST LINCOLN AVENUE, 1ST REVISION
 SW1/4 SECTION 9 AND NW1/4 SECTION 16, TOWNSHIP 6 SOUTH,
 RANGE 66 WEST OF THE 6TH P.M.
 TOTAL AREA 14.87 ACRES - LEASE AREA 480 SQUARE FEET SITE
 IMPROVEMENT PLAN SP2012-015

ANTENNA CENTROID
 LAT. = N39°32'13.5141"
 LONG. = W104°47'13.6840"

MONUMENT "A"
 FOUND 1/4 CORNER 3.25"
 ALUMINUM CAP LS 11989

TRACT F
 CHALLENGER PARK ESTATES #2
 TOWN OF PARKER ZONING:
 PLANNED DEVELOPMENT

TRACT F
 CHALLENGER PARK ESTATES #2
 TOWN OF PARKER ZONING:
 PLANNED DEVELOPMENT

FOUND SECTION CORNER
 3.25" ALUMINUM CAP LS 2305.3
 IN RANGE BOX

ITEM 21 EXISTING
 50' SANITARY SEWER EASEMENT
 DB:1221; PG: 2013
 DB: 1461; PG: 1269

PROPOSED 18'X30'
 LEASE AREA
 REC'D

OWNER:
 DOUGLAS COUNTY BOARD
 OF COUNTY COMMISSIONERS
 DOUGLAS COUNTY ZONING:
 PDU
 PLANNED DEVELOPMENT
 (URBAN)

EXISTING 80' GAS
 EASEMENT
 DB:189; PG: 32
 DB:1101; PG:1306

PROPOSED
 5' UTILITY EASEMENT
 BY TRUE NORTH
 SURVEYING & MAPPING
 REC'D

OWNER:
 DOUGLAS COUNTY BOARD OF COUNTY COMMISSIONERS
 DOUGLAS COUNTY ZONING:
 PDU PLANNED DEVELOPMENT (URBAN)

ITEM 22 EXISTING
 10' ELECTRIC EASEMENT
 DB:1148; PG: 1036

L=272.63'
 Δ=303°4'43"
 CHORD BRG.=S24°11'04"W
 CHORD DIST.=269.40'
 R=510.83'

L=111.55'
 Δ=124°53"
 CHORD BRG.=S12°39'43"W
 CHORD DIST.=111.32'
 R=200.00'

OWNER:
 TOWN OF PARKER
 PUBLIC FACILITY

ITEM 22 EXISTING
 30' SANITARY SEWER EASEMENT
 DB:1221; PG: 2013
 DB: 1461; PG: 1269

ITEM 23 EXISTING
 50'X50' SANITARY SEWER EASEMENT
 DB:1221; PG: 2013
 DB: 1461; PG: 1269

ITEM 23 EXISTING
 WATERWELL EASEMENT
 DB: 1221 PG: 2008

ITEM 23 EXISTING
 30' WATERLINE EASEMENT
 DB: 1221 PG: 2008

COLORADO LANDLORD REPRESENTATIVE ACKNOWLEDGEMENT

STATE OF COLORADO)
)ss.
COUNTY OF _____)

The foregoing instrument was acknowledged before me this ____ day of _____ 201__, by _____, the _____ of _____.

Notary Seal

(Signature of Notary)
My Commission Expires: _____

TENANT ACKNOWLEDGEMENT

STATE OF COLORADO)
)ss.
COUNTY OF _____)

The foregoing instrument was acknowledged before me this ____ day of _____ 201__, by _____, the _____ of AT&T Mobility Corporation.

Notary Seal

(Signature of Notary)
My Commission Expires: _____

After Recording Return to:

New Cingular Wireless PCS, LLC
Attn: Network Real Estate Admin.
575 Morosgo Dr. NE
Suite 13F, West Tower
Atlanta, GA 30324

(Space Above this Line for Recorder's Use Only)

APN (Tax ID): _____
Cell Site #:80818-A, Cell Site Name: Lincoln & Jordan (CO),
FA No: 10099211
State: COLORADO
County: DOUGLAS

**SECOND AMENDMENT TO MEMORANDUM
OF
LEASE**

This Second Amendment to Memorandum of Lease is entered into on this 4th day of NOV., 2014, by and between the Douglas County Board of County Commissioners, State of Colorado, having a mailing address of 100 Third Street, Castle Rock, CO 80104 ("**Landlord**") and New Cingular Wireless PCS, LLC, a Delaware limited liability company, having a mailing address of 575 Morosgo Dr. NE, Suite 13F, West Tower, Atlanta, GA 30324 ("**Tenant**").

1. Landlord and Tenant entered into a certain Communications Site Lease Agreement dated February 21, 2006, as amended by that certain First Amendment to Communications Site Lease dated April 24, 2012, (collectively, the "**Agreement**") for the purpose of installing, operating and maintaining a communications facility and other improvements. A Memorandum of Lease reflecting the Agreement was recorded May 9, 2012, with a recording number of #2012033875 in the public records of Douglas County, State of Colorado.
2. Landlord agrees to increase the size of the Premises to accommodate a permanent generator and all required utilities. Landlord leases to Tenant the Premises as more completely

12-2010
2010 Form Amendment

described on **Exhibit B-2**, attached hereto and incorporated herein. **Exhibit B-2** hereby replaces **Exhibit B-1** to the Agreement.

3. This Second Amendment to Memorandum of Lease is not intended to amend or modify, and shall not be deemed or construed as amending or modifying, any of the terms, conditions or provisions of the Agreement, all of which are hereby ratified and affirmed. In the event of a conflict between the provisions of this Second Amendment to Memorandum of Lease and the provisions of the Agreement, the provisions of the Agreement shall control. The Agreement shall be binding upon and inure to the benefit of the parties and their respective heirs, successors, and assigns, subject to the provisions of the Agreement.

IN WITNESS WHEREOF, the parties have executed this [First, Second, Third] Amendment to Memorandum of Lease as of the day and year first above written.

"LANDLORD"

Douglas County Board of County
Commissioners, State of Colorado

By: 

Print Name: Roger Partridge, chair

Its: _____

Date: _____

Approved as to Fiscal Content:

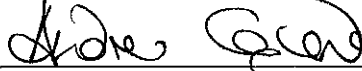

Andrew Copland, Director of Finance

Approved as to Content:



Douglas J. DeBord, County Manager

Approved as to Legal Form:

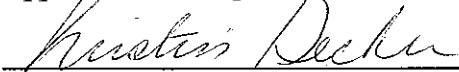

Kristin Decker, Sr. Asst. County Attorney

"TENANT"

New Cingular Wireless PCS, LLC,
a Delaware limited liability company
By: AT&T Mobility Corporation
Its: Manager

By: Becky Ann Harvey
Print Name: Becky Ann Harvey
Its: Area Manager Site Mod SAG
Date: 6-3-2014

TENANT ACKNOWLEDGEMENT

STATE OF Colorado)
) ss:
COUNTY OF Arapahoe)

On the 4 day of June, 2014, before me personally appeared Becky John-Amy and acknowledged under oath that she is the AREA MANAGER, SITE MGR SAQ of New Cingular Wireless ACS, LLC, the Tenant named in the attached instrument, and as such was authorized to execute this instrument on behalf of the AT+T mobility Corp.

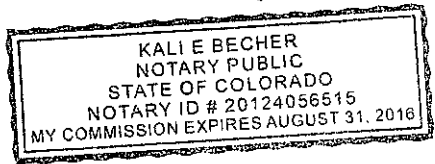

[Signature]
Notary Public: Kalie Becher
My Commission Expires: 8/31/16

COLORADO LANDLORD REPRESENTATIVE ACKNOWLEDGEMENT

STATE OF COLORADO)
) ss:
COUNTY OF DOUGLAS)

BE IT REMEMBERED, that on this 4th day of November, 2014, before me, the subscriber, a person authorized to take oaths in the State of Colorado, personally appeared Roger Partridge who, being duly sworn on his/her/their oath, deposed and made proof to my satisfaction that he/she/they is/are the person(s) named in the within instrument; and I, having first made known to him/her/them the contents thereof, he/she/they did acknowledge that he/she/they signed, sealed and delivered the same as his/her/their voluntary act and deed for the purposes therein contained.

[Signature]
Notary Public: Amy T. Williams
My Commission Expires: _____

COLORADO LANDLORD REPRESENTATIVE ACKNOWLEDGEMENT

STATE OF COLORADO)

) ss:

COUNTY OF DOUGLAS)

BE IT REMEMBERED, that on this ____ day of _____, 2014_ before me, the subscriber, a person authorized to take oaths in the State of Colorado, personally appeared _____ who, being duly sworn on his/her/their oath, deposed and made proof to my satisfaction that he/she/they is/are the person(s) named in the within instrument; and I, having first made known to him/her/them the contents thereof, he/she/they did acknowledge that he/she/they signed, sealed and delivered the same as his/her/their voluntary act and deed for the purposes therein contained.

Notary Public: _____

My Commission Expires: _____

COLORADO LANDLORD REPRESENTATIVE ACKNOWLEDGEMENT

STATE OF COLORADO)

) ss:

COUNTY OF DOUGLAS)

BE IT REMEMBERED, that on this ____ day of _____, 2014_ before me, the subscriber, a person authorized to take oaths in the State of Colorado, personally appeared _____ who, being duly sworn on his/her/their oath, deposed and made proof to my satisfaction that he/she/they is/are the person(s) named in the within instrument; and I, having first made known to him/her/them the contents thereof, he/she/they did acknowledge that he/she/they signed, sealed and delivered the same as his/her/their voluntary act and deed for the purposes therein contained.

Notary Public: _____

My Commission Expires: _____

COLORADO LANDLORD REPRESENTATIVE ACKNOWLEDGEMENT

STATE OF COLORADO)

) ss:

COUNTY OF DOUGLAS)

BE IT REMEMBERED, that on this ____ day of _____, 2014_ before me, the subscriber, a person authorized to take oaths in the State of Colorado, personally appeared _____ who, being duly sworn on his/her/their oath, deposed and made proof to my satisfaction that he/she/they is/are the person(s) named in the within instrument; and I, having first made known to him/her/them the contents thereof, he/she/they did acknowledge that he/she/they signed, sealed and delivered the same as his/her/their voluntary act and deed for the purposes therein contained.

Notary Public: _____

My Commission Expires: _____

EXHIBIT B-2

12-2010
2010 Form Amendment

GENERAL DYNAMICS Wireless Services

LINCOLN & JORDAN COU1431

LATITUDE: 39° 32' 11.13" N
LONGITUDE: 104° 47' 14.651" W
F.A.# 10099211
GENERATORS

SHEET INDEX

TITLE SHEET

A1	ARCHITECTURAL
A2	GENERAL CONSTRUCTION NOTES
A3	OVERALL EXHIBITED PROPOSED SITE PLANS
A4	BALANCE PLAN
A5	GENERATION DETAILS
A6	GENERAL DETAILS
A7	MECHANICAL
A8	FOUNDATION PLANS & NOTES
A9	ELECTRICAL
A10	BASE LINE DIAGRAM
A11	GROUNDING DETAILS
A12	PANEL SCHEDULE

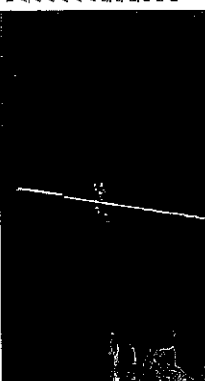

SITE PHOTO

GENERAL NOTES

CONTRACTOR SHALL VERIFY ALL DIMENSIONS AND LOCATIONS OF ALL EXISTING UTILITIES AND STRUCTURES. CONTRACTOR SHALL VERIFY ALL DIMENSIONS AND LOCATIONS OF ALL EXISTING UTILITIES AND STRUCTURES. CONTRACTOR SHALL VERIFY ALL DIMENSIONS AND LOCATIONS OF ALL EXISTING UTILITIES AND STRUCTURES.

PROJECT DATA

JURISDICTION: DOUGLAS COUNTY
ZONING: PD PLANNED DEVELOPMENT
EXISTING REGULATIONS: UNIMMUNED TELECOMMUNICATION CELLITE
CONSTRUCTION TYPE: V
AREA: 400 SQ. FT. (NET EQUIPMENT AREA)

PROJECT INFORMATION

PROPERTY OWNER: DOUGLAS COUNTY BOARD OF COMMISSIONERS
ADDRESS: 700 S. 14TH ST. SUITE 100
LINCOLN, NE 68502

ENGINEERING

DESIGNER: GENERAL DYNAMICS
DATE: 08/17/2011
SCALE: AS SHOWN

PROJECT DESCRIPTION

INSTALLATION OF TWO (2) 150W BROADBAND WIRELESS ACCESS POINTS AND PROPOSED DIESEL GENERATOR AND PROPOSED DIESEL SWM GENERATOR.

APPROVALS

TITLE	DATE
DESIGNED BY	
CHECKED BY	
APPROVED BY	
DATE	

PROJECT DESCRIPTION

INSTALLATION OF TWO (2) 150W BROADBAND WIRELESS ACCESS POINTS AND PROPOSED DIESEL GENERATOR AND PROPOSED DIESEL SWM GENERATOR.

PROPERTY OWNER: DOUGLAS COUNTY BOARD OF COMMISSIONERS
ADDRESS: 700 S. 14TH ST. SUITE 100
LINCOLN, NE 68502

APPROVALS

TITLE	DATE
DESIGNED BY	
CHECKED BY	
APPROVED BY	
DATE	

GENERAL NOTES

CONTRACTOR SHALL VERIFY ALL DIMENSIONS AND LOCATIONS OF ALL EXISTING UTILITIES AND STRUCTURES. CONTRACTOR SHALL VERIFY ALL DIMENSIONS AND LOCATIONS OF ALL EXISTING UTILITIES AND STRUCTURES. CONTRACTOR SHALL VERIFY ALL DIMENSIONS AND LOCATIONS OF ALL EXISTING UTILITIES AND STRUCTURES.

PROJECT INFORMATION

PROPERTY OWNER: DOUGLAS COUNTY BOARD OF COMMISSIONERS
ADDRESS: 700 S. 14TH ST. SUITE 100
LINCOLN, NE 68502

APPROVALS

TITLE	DATE
DESIGNED BY	
CHECKED BY	
APPROVED BY	
DATE	

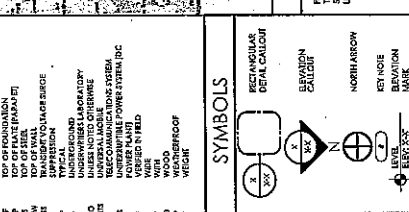
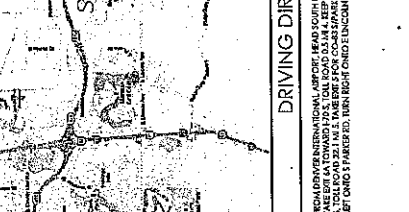

SYMBOLS

(Symbol)	RECTANGULAR DETAIL CALLOUT
(Symbol)	BLIND
(Symbol)	NORTH ARROW
(Symbol)	EXISTING ELEVATION MARK
(Symbol)	PROPOSED ELEVATION MARK

ABBREVIATIONS

AT	ARCHITECTURAL	AC	ACROBATIC
AV	AIR VENT	AD	ADJUSTABLE
AVL	AIR VENT LAMP	ADJ	ADJUSTABLE
AVL	AIR VENT LAMP	ADJ	ADJUSTABLE
AVL	AIR VENT LAMP	ADJ	ADJUSTABLE



2000 JENNIFER BLVD
DENVER, CO 80202

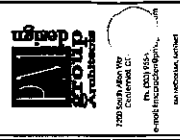

7200 SOUTH ARROYO WAY
DENVER, CO 80231
PH: 303.955.8000
WWW.P&G.COM

DATE	01/13/2011
BY	CHANDRA SETHI
CHECKED	
DESIGNED	
REVISION	
MADE	

Sheet

SITE NAME:
LINCOLN & JORDAN
PA # 0099211

SITE ADDRESS:
1738 E LINCOLN AVE
SPARKER, CO 80134

Project Number:
GDT14002.0

Overall & Enlarged
Proposed Site Plan

Sheet Number
A-2

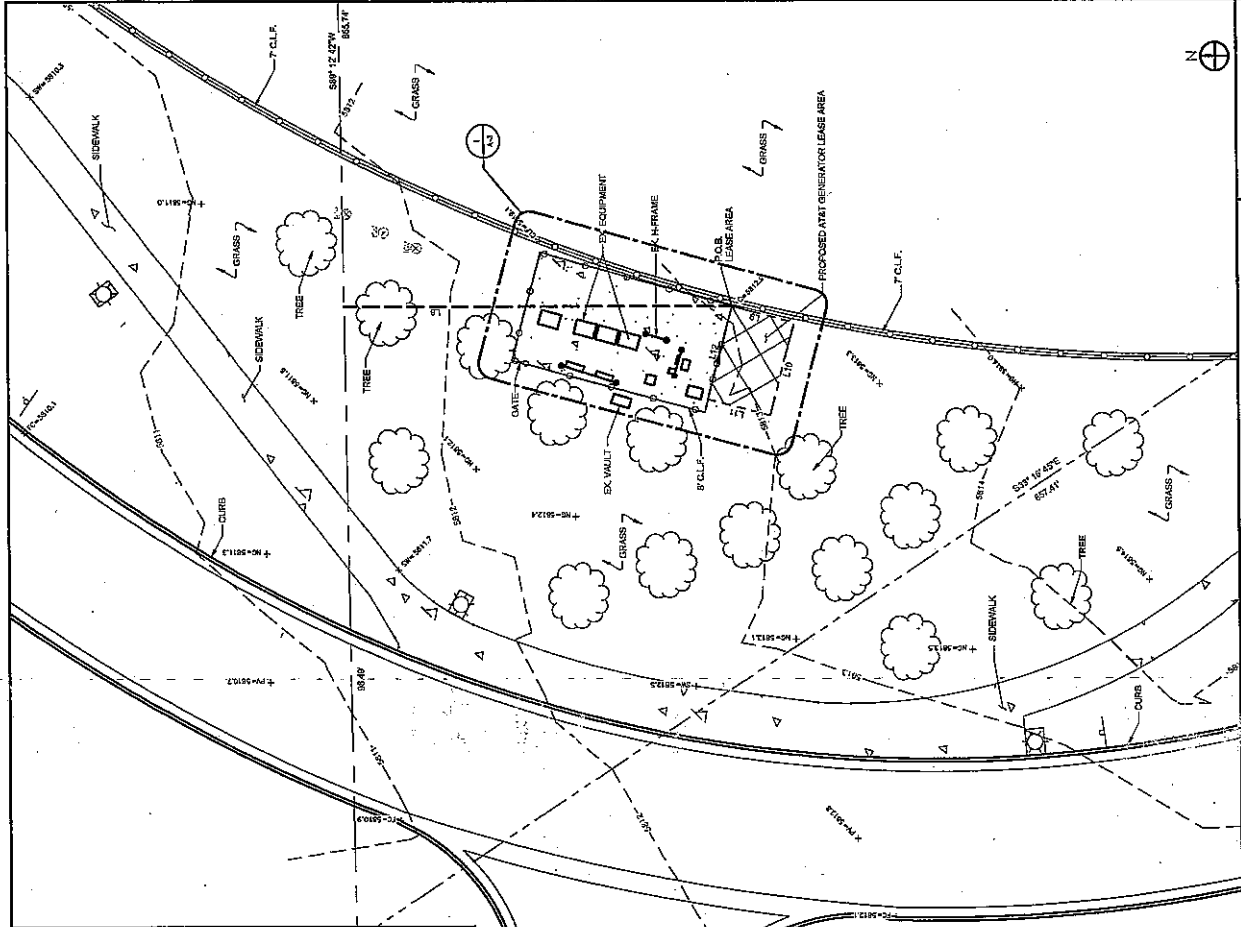

NO SCALE

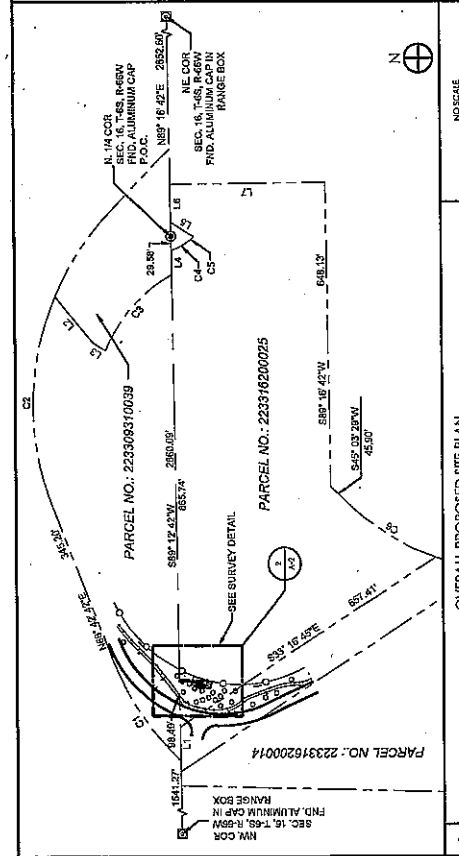

OVERALL PROPOSED SITE PLAN

NO SCALE

ENLARGED PROPOSED SITE PLAN

2



2000 H. LINCOLN AVE., 4TH FLOOR
FRODO/AL/15050

GENERAL INQUIRIES
Lynch Design Inc. Inc
3445 E. INGLEWOOD BL., SUITE A
DENVER, CO 80238

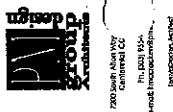

7200 South Alamo Way
Centennial, CO
771.480.1912
lynchdesign.com

MARK	DATE	REVISION



THE NAME:
LINCOLN & JORDAN
PART #1009211

THE ADDRESS:
17356 LINCOLN AVE
PARKER, CO 80134

PROJECT NUMBER
GDT14002.0

SHEET NUMBER
GENERATOR
DETAILS

DATE PLOTTED
A-4

OUTDOOR GENERATOR INFORMATION:
1. THE BRANDS USE OF THE DESIGNATION "EMERGENCY USE ONLY" DOES NOT IMPLY THAT THE GENERATOR WAS DESIGNED OR RATED FOR EMERGENCY USE. IT IS THE USER'S RESPONSIBILITY TO ENSURE THE GENERATOR IS USED IN ACCORDANCE WITH THE MANUFACTURER'S INSTRUCTIONS AND TO MAINTAIN THE GENERATOR AT THE SECOND LEVEL OF NORMAL CONCENTRATION BETWEEN PEOPLE (PO DISCSES)

STANDARD FEATURES:

- * KOHLER: CO. PROVIDES ONGOING RESPONSIBILITY FOR THE GENERATOR SYSTEM AND ACCESSORIES.
- * THE GENERATOR SET AND ITS COMPONENTS ARE PHOTOGRAPHED, FACTOR-MATED, AND PHOTOGRAPHED.
- * THE GEN. GENERATOR SET HAS A UL 200 LISTING
- * THE GENERATOR SET ACCEPTS BATED LOAD IN ONE STEP
- * THE GEN. GENERATOR SET MEETS NFPA 118, LEVEL 1.
- * A ONE-YEAR BASIC LIMITED WARRANTY COVERS ALL SYSTEMS AND COMPONENTS. A FIVE-YEAR EXTENDED WARRANTY IS ALSO AVAILABLE
- * THE BASIC FULL-RESPONSE EXCITATION SYSTEM DELIVERS EXCELLENT VOLTAGE RESPONSE AND SHORT CIRCUIT CAPABILITY USING A FASTER, MORE SENSITIVE, MORE PRECISELY TUNED, AND MORE RESPONSIVE
- * INTEGRAL VIBRATION ISOLATION REDUCES THE NEED FOR UNDESIRABLE VIBRATION ISOLATION.
- * SOUND ATTENUATION ENCLOSURE HAS A SOUND PRESSURE LEVEL OF 60DB(A) AT 7M (23FT).
- * THE DESIGN OF THE GENERATOR SET MEETS ALL LOCAL AND STATE ALL HAZARDOUS MATERIAL HANDLING REQUIREMENTS AND IS DESIGNED FOR EASY REMOVAL FROM THE GENERATOR SET AND STORAGE.
- * THE DESIGN ALSO PROVIDES THE NON-HAZARDOUS FUEL TANK AND FUEL SYSTEMS TO MEET ALL LOCAL AND STATE ALL HAZARDOUS MATERIAL HANDLING REQUIREMENTS AND IS DESIGNED FOR EASY REMOVAL FROM THE GENERATOR SET AND STORAGE.

- * THE GENERATOR SET HAS ACCESSIBILITY TO ALL ROUTINE SERVICED COMPONENTS INCLUDING:
-AIR FILTER
-BATTERY
-FUEL INJECTOR
-OIL FILTER

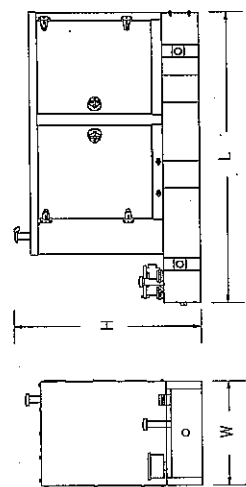
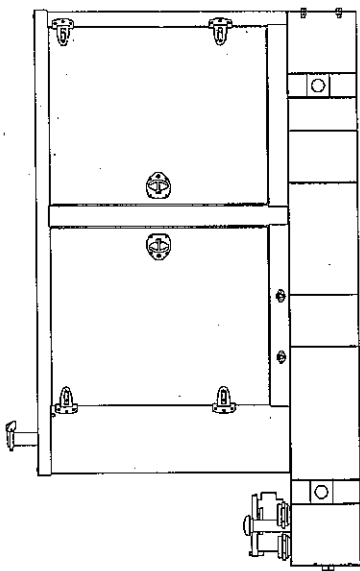

DIMENSIONS AND WEIGHTS:
ENCLOSURE: 60" W x 100" H x 30" D (1524 x 2540 x 762)
GENERATOR SET: 60" W x 100" H x 30" D (1524 x 2540 x 762)
TOTAL: 120" W x 100" H x 30" D (3048 x 2540 x 762)
NOTE: THE WEIGHTS PROVIDED FOR REFERENCE ONLY AND SHOULD NOT BE USED FOR PLANNING INSTALLATION. CONTACT YOUR LOCAL DISTRIBUTOR FOR MORE DETAILED INFORMATION.

DIESEL GENERATOR DETAILS

NO SCALE

1

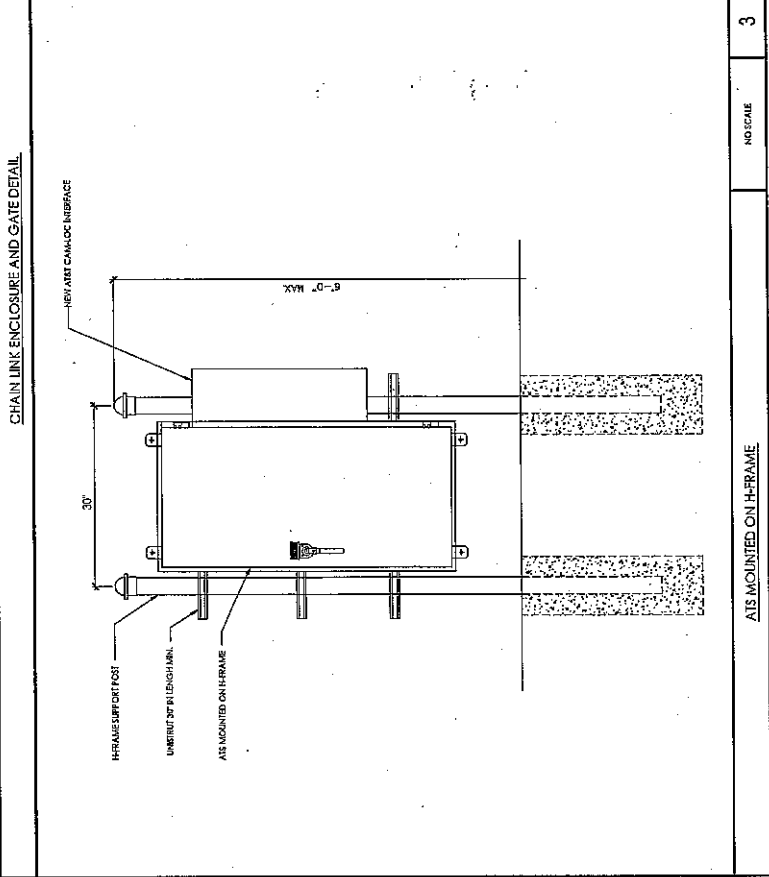
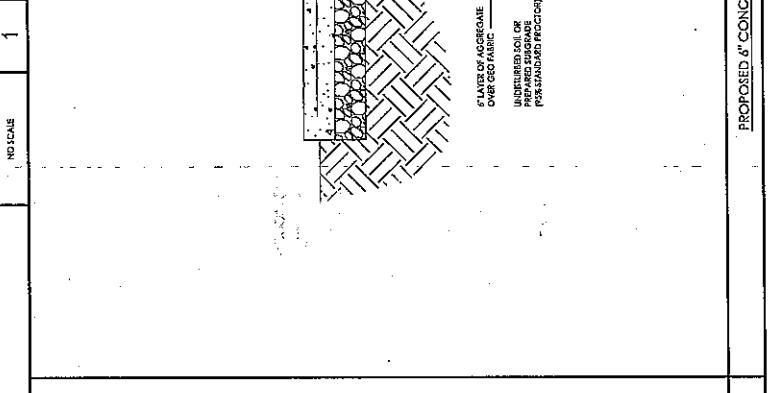
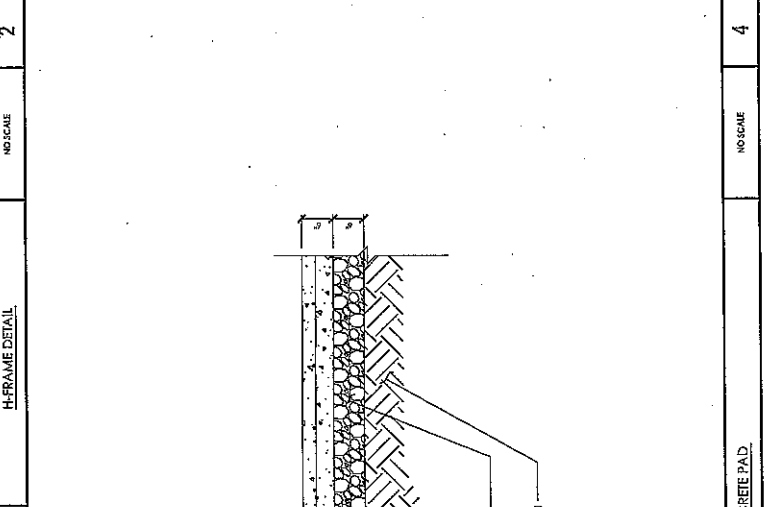
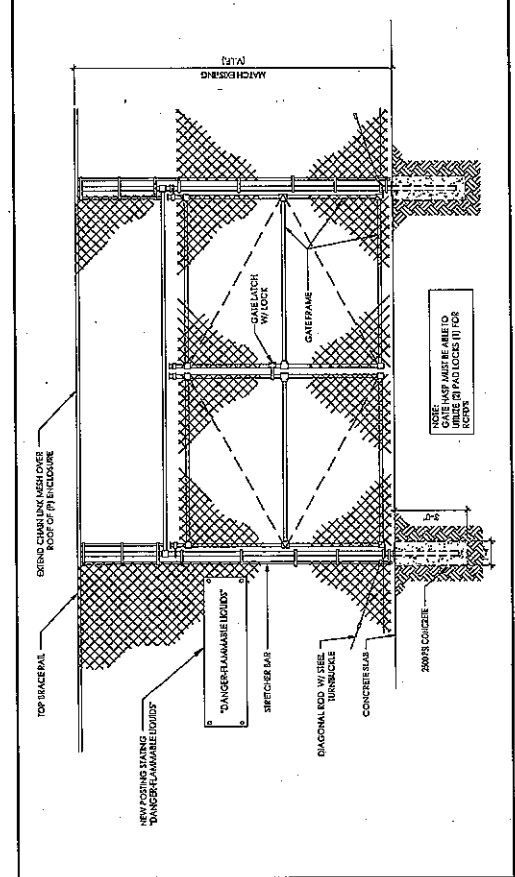
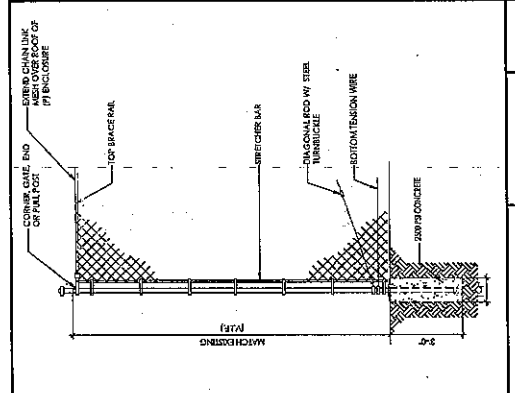
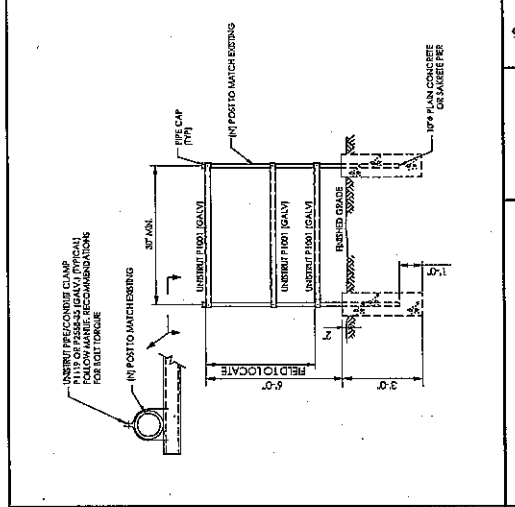

DATE	DESCRIPTION
04/17/2014	CREATED
04/18/2014	REVISION
04/23/2014	REVISION
04/24/2014	REVISION
04/25/2014	REVISION
04/26/2014	REVISION
04/27/2014	REVISION
04/28/2014	REVISION
04/29/2014	REVISION
04/30/2014	REVISION
05/01/2014	REVISION
05/02/2014	REVISION
05/03/2014	REVISION
05/04/2014	REVISION
05/05/2014	REVISION
05/06/2014	REVISION
05/07/2014	REVISION
05/08/2014	REVISION
05/09/2014	REVISION
05/10/2014	REVISION
05/11/2014	REVISION
05/12/2014	REVISION
05/13/2014	REVISION
05/14/2014	REVISION
05/15/2014	REVISION
05/16/2014	REVISION
05/17/2014	REVISION
05/18/2014	REVISION
05/19/2014	REVISION
05/20/2014	REVISION
05/21/2014	REVISION
05/22/2014	REVISION
05/23/2014	REVISION
05/24/2014	REVISION
05/25/2014	REVISION
05/26/2014	REVISION
05/27/2014	REVISION
05/28/2014	REVISION
05/29/2014	REVISION
05/30/2014	REVISION
05/31/2014	REVISION

PROJECT NUMBER	GDTI 4002.0
OWNER	UNICOIN & JORDAN PA # 10092911
DESIGNER	PAUL GROUP 17300 E UNICOIN AVE PARKER, CO 80134
FOUNDATION PLAN & NOTES	
SCALE	S-1

GENERAL NOTES

1. THESE DRAWINGS DO NOT INCLUDE NECESSARY COMPONENTS FOR CONSTRUCTION SAFETY.

2. ALL TEMPORARY BRACING AND SHORING SHALL BE DESIGNED AND CONSTRUCTED IN ACCORDANCE WITH THE LATEST EDITIONS OF THE AISC MANUAL OF STEEL CONSTRUCTION AND THE ACI BUILDING CODES.

3. ALL DIMENSIONS ON THE STRUCTURAL DRAWINGS SHALL BE GIVEN UNLESS OTHERWISE NOTED.

4. THE ARCHITECT AND ENGINEER SHALL BE RESPONSIBLE FOR THE DESIGN OF THE FOUNDATION.

5. REFER TO MECHANICAL, ELECTRICAL AND INSTRUMENTATION DRAWINGS FOR DETAILS OF THE FOUNDATION.

6. THE FOUNDATION HAS BEEN DESIGNED BASED ON LOADS PROVIDED BY THE ARCHITECT AND ENGINEER. THE ARCHITECT AND ENGINEER SHALL BE RESPONSIBLE FOR THE DESIGN OF THE FOUNDATION.

7. THE FOUNDATION SHALL BE CONSTRUCTED IN ACCORDANCE WITH THE LATEST EDITIONS OF THE AISC MANUAL OF STEEL CONSTRUCTION AND THE ACI BUILDING CODES.

8. THE FOUNDATION SHALL BE CONSTRUCTED IN ACCORDANCE WITH THE LATEST EDITIONS OF THE AISC MANUAL OF STEEL CONSTRUCTION AND THE ACI BUILDING CODES.

9. THE FOUNDATION SHALL BE CONSTRUCTED IN ACCORDANCE WITH THE LATEST EDITIONS OF THE AISC MANUAL OF STEEL CONSTRUCTION AND THE ACI BUILDING CODES.

10. THE FOUNDATION SHALL BE CONSTRUCTED IN ACCORDANCE WITH THE LATEST EDITIONS OF THE AISC MANUAL OF STEEL CONSTRUCTION AND THE ACI BUILDING CODES.

MEANS AND METHODS	DESIGN CRITERIA
FOUNDATIONS	FOUNDATIONS SHALL BE CONSTRUCTED IN ACCORDANCE WITH THE LATEST EDITIONS OF THE AISC MANUAL OF STEEL CONSTRUCTION AND THE ACI BUILDING CODES.
CONCRETE	CONCRETE SHALL BE CONSTRUCTED IN ACCORDANCE WITH THE LATEST EDITIONS OF THE AISC MANUAL OF STEEL CONSTRUCTION AND THE ACI BUILDING CODES.
STEEL	STEEL SHALL BE CONSTRUCTED IN ACCORDANCE WITH THE LATEST EDITIONS OF THE AISC MANUAL OF STEEL CONSTRUCTION AND THE ACI BUILDING CODES.

GENERAL NOTES

1. THESE DRAWINGS DO NOT INCLUDE NECESSARY COMPONENTS FOR CONSTRUCTION SAFETY.

2. ALL TEMPORARY BRACING AND SHORING SHALL BE DESIGNED AND CONSTRUCTED IN ACCORDANCE WITH THE LATEST EDITIONS OF THE AISC MANUAL OF STEEL CONSTRUCTION AND THE ACI BUILDING CODES.

3. ALL DIMENSIONS ON THE STRUCTURAL DRAWINGS SHALL BE GIVEN UNLESS OTHERWISE NOTED.

4. THE ARCHITECT AND ENGINEER SHALL BE RESPONSIBLE FOR THE DESIGN OF THE FOUNDATION.

5. REFER TO MECHANICAL, ELECTRICAL AND INSTRUMENTATION DRAWINGS FOR DETAILS OF THE FOUNDATION.

6. THE FOUNDATION HAS BEEN DESIGNED BASED ON LOADS PROVIDED BY THE ARCHITECT AND ENGINEER. THE ARCHITECT AND ENGINEER SHALL BE RESPONSIBLE FOR THE DESIGN OF THE FOUNDATION.

7. THE FOUNDATION SHALL BE CONSTRUCTED IN ACCORDANCE WITH THE LATEST EDITIONS OF THE AISC MANUAL OF STEEL CONSTRUCTION AND THE ACI BUILDING CODES.

8. THE FOUNDATION SHALL BE CONSTRUCTED IN ACCORDANCE WITH THE LATEST EDITIONS OF THE AISC MANUAL OF STEEL CONSTRUCTION AND THE ACI BUILDING CODES.

9. THE FOUNDATION SHALL BE CONSTRUCTED IN ACCORDANCE WITH THE LATEST EDITIONS OF THE AISC MANUAL OF STEEL CONSTRUCTION AND THE ACI BUILDING CODES.

10. THE FOUNDATION SHALL BE CONSTRUCTED IN ACCORDANCE WITH THE LATEST EDITIONS OF THE AISC MANUAL OF STEEL CONSTRUCTION AND THE ACI BUILDING CODES.

MEANS AND METHODS	DESIGN CRITERIA
FOUNDATIONS	FOUNDATIONS SHALL BE CONSTRUCTED IN ACCORDANCE WITH THE LATEST EDITIONS OF THE AISC MANUAL OF STEEL CONSTRUCTION AND THE ACI BUILDING CODES.
CONCRETE	CONCRETE SHALL BE CONSTRUCTED IN ACCORDANCE WITH THE LATEST EDITIONS OF THE AISC MANUAL OF STEEL CONSTRUCTION AND THE ACI BUILDING CODES.
STEEL	STEEL SHALL BE CONSTRUCTED IN ACCORDANCE WITH THE LATEST EDITIONS OF THE AISC MANUAL OF STEEL CONSTRUCTION AND THE ACI BUILDING CODES.

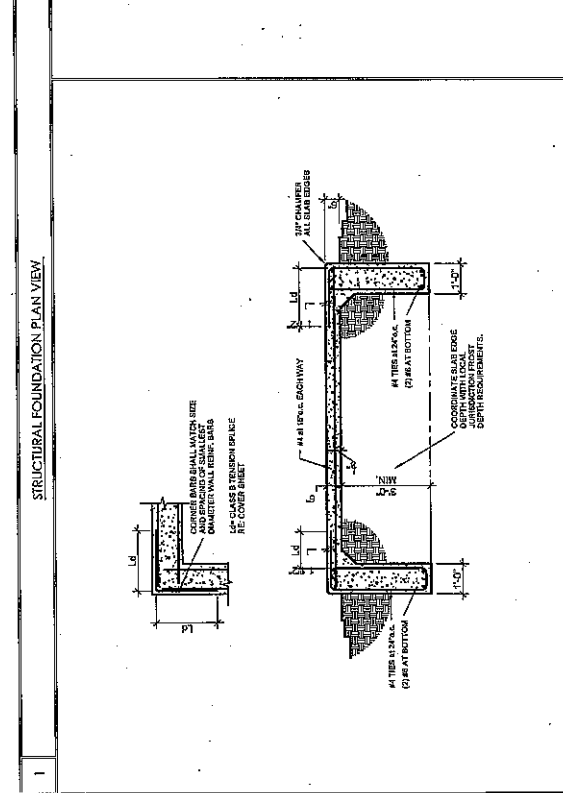
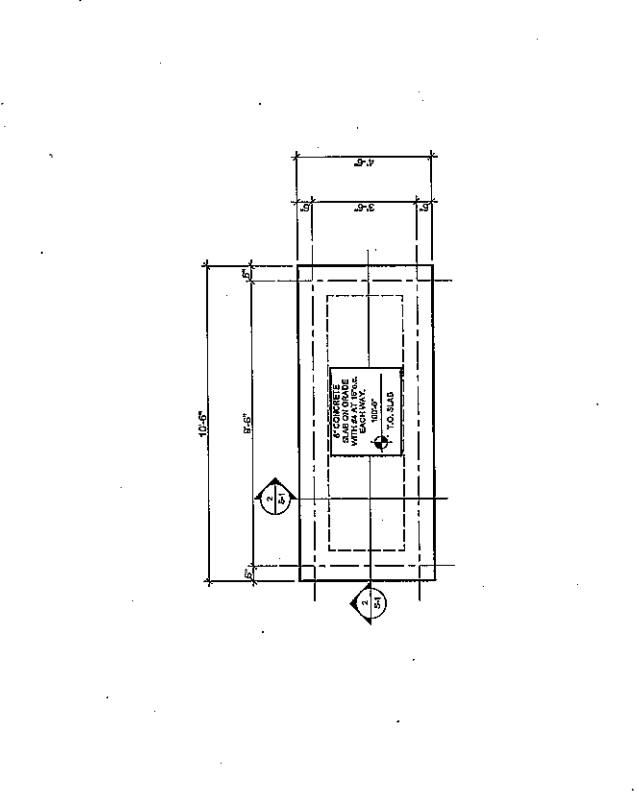
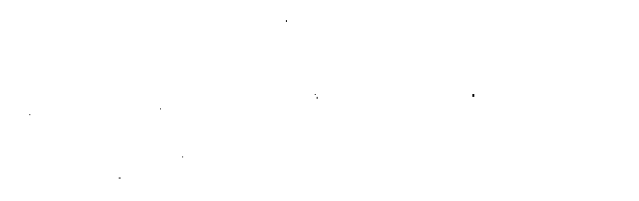

188 GENERATOR ROOM SHOVE 188 GENERATOR FIRE LEAK 188 GENERATOR FIRE LOW 188 GENERATOR FUEL 188 GENERATOR MAIN 188 GENERATOR WINDING 188 GENERATOR SHEET DOWN 188 GENERATOR SHEET UP 188 GEN BATT CHARGER FAIL	CRITICAL CRITICAL CRITICAL CRITICAL MAJOR MAJOR CRITICAL CRITICAL CRITICAL CRITICAL CRITICAL CRITICAL
188 GEN BATT CHARGER FAIL 188 GENERATOR FIRE LEAK 188 GENERATOR FIRE LOW 188 GENERATOR FUEL 188 GENERATOR MAIN 188 GENERATOR WINDING 188 GENERATOR SHEET DOWN 188 GENERATOR SHEET UP 188 GEN BATT CHARGER FAIL	CRITICAL CRITICAL CRITICAL CRITICAL MAJOR MAJOR CRITICAL CRITICAL CRITICAL CRITICAL CRITICAL CRITICAL

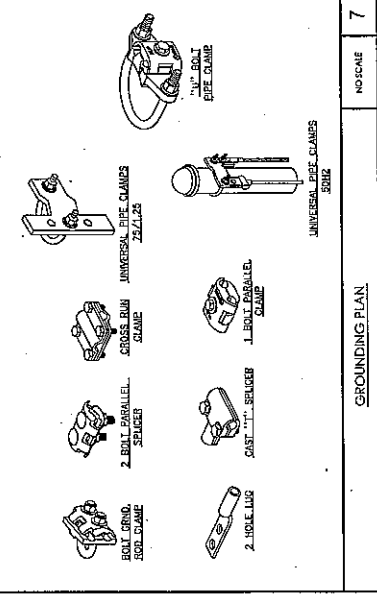
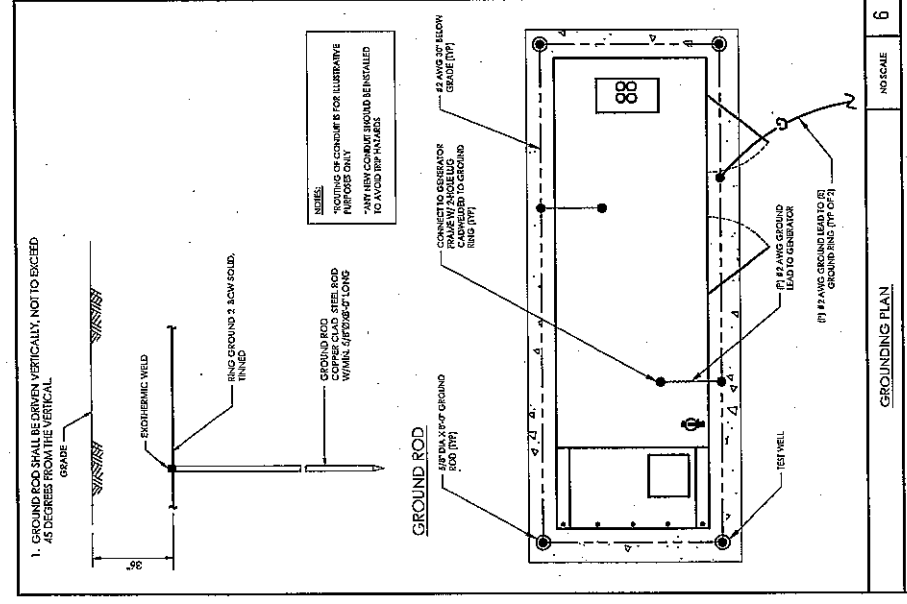
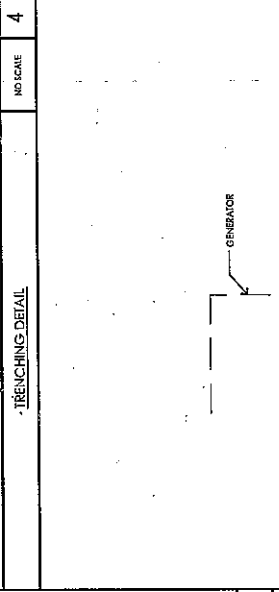
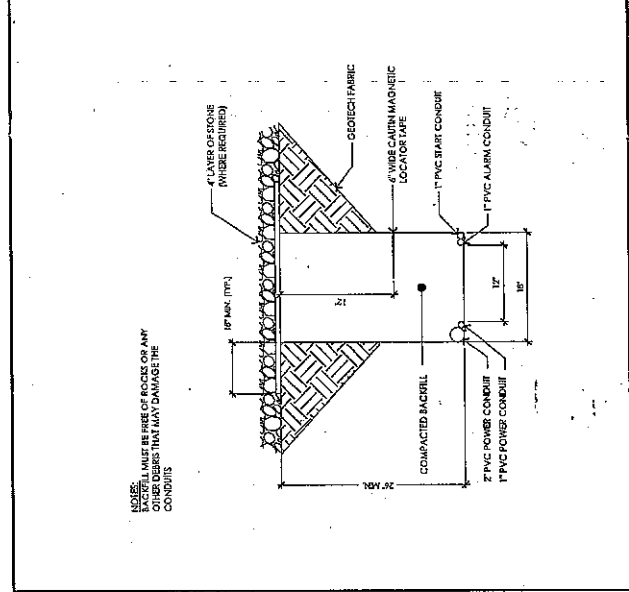
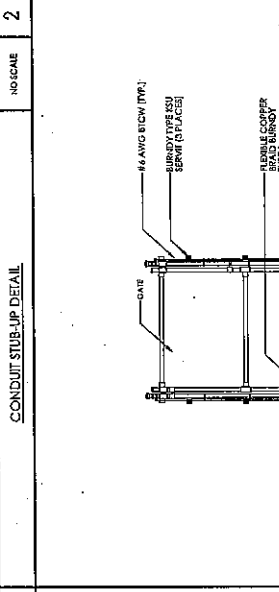
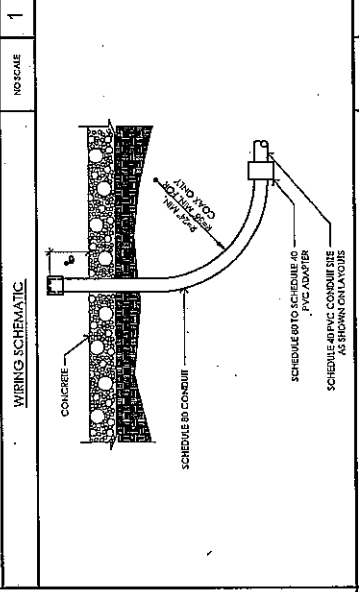

Market: Colorado
Cell Site Number: COL01431
Cell Site Name: Lincoln & Jordan
Fixed Asset Number: 10099211

THIRD AMENDMENT TO COMMUNICATIONS SITE LEASE AGREEMENT

THIS THIRD AMENDMENT TO COMMUNICATIONS SITE LEASE AGREEMENT ("Amendment"), dated as of the latter of the signature dates below, is by and between Douglas County, Board of Commissioners, having a mailing address of 100 Third Street, Castle Rock, Colorado 80104 ("Landlord") and New Cingular Wireless PCS, LLC, a Delaware limited liability company, having a mailing address of 575 Morosgo Drive, Atlanta, GA 30324 ("Tenant").

WHEREAS, Landlord and Tenant entered into a Communications Site Lease Agreement dated February 21, 2006, as further amended by that First Amendment to Communications Site Lease Agreement dated April 24, 2012, as further amended by Second Amendment to Communications Site Lease Agreement dated November 4, 2014 whereby Landlord leased to Tenant certain Premises, therein described, that are a portion of the Property located at 17305 East Lincoln Avenue, Parker, Colorado 80134 ("Agreement"); and

WHEREAS, Landlord and Tenant desire to amend the Agreement to increase the size of the Premises; and

WHEREAS, Landlord and Tenant desire to amend the Agreement to permit Tenant to add, modify and/or replace equipment in order to be in compliance with any current or future federal, state or local mandated application, including but not limited to emergency 911 communication services.

NOW THEREFORE, in consideration of the foregoing and other good and valuable consideration, the receipt and sufficiency of which are hereby acknowledged, Landlord and Tenant agree as follows:

1. **Premises.** Upon full execution of this Amendment, Landlord hereby grants Tenant an additional 96 square feet of lease space for a total leased Premises of 726 square feet as shown in Exhibit B-3. Tenant's proposed modifications to the Premises are more particularly described on Exhibit B-3, which shall supersede and replace Exhibit B-2 of the Agreement. Landlord's execution of this Third Amendment will signify Landlord's approval of Exhibit B-3.
2. **Emergency 911 Service.** In the future, without the payment of additional Rent and with a scope of work mutually acceptable to Landlord and Tenant, Landlord agrees that Tenant may add, modify and/or replace equipment in order to be in compliance with any current or future federal, state or local mandated application, including but not limited to emergency 911 communication services.
3. **Other Terms and Conditions Remain.** In the event of any inconsistencies between the Agreement and this Amendment, the terms of this Amendment shall control. Except as expressly set forth in this Amendment, the Lease otherwise is unmodified and remains in full force and effect. Each reference in the Lease to itself shall be deemed also to refer to this Amendment.
4. **Capitalized Terms.** All capitalized terms used but not defined herein shall have the same meanings as defined in the Lease.

IN WITNESS WHEREOF, the parties have caused this Amendment to be effective as of the last date written below.

LANDLORD:
Douglas County, Board of Commissioners

TENANT:
New Cingular Wireless PCS, LLC,
a Delaware limited liability company

By: AT&T Mobility Corporation
Its: Manager

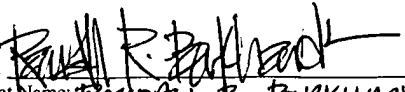
By: 
Print Name: RANDALL R. BURKHARDT
Its: ASST. DIRECTOR OF PARKS
Date: 01.27.17

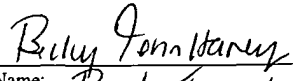
By: 
Print Name: Becky John Itaney
Its: Area manager
Date: 7/31/2017

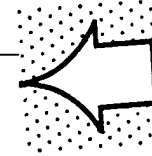

LANDLORD INDIVIDUAL ACKNOWLEDGMENT - COLORADO

STATE OF Colorado)
)ss.
COUNTY OF Douglas)

The foregoing instrument was acknowledged before me this 27 day of July 2017, by RANDALL R. BURKHARDT

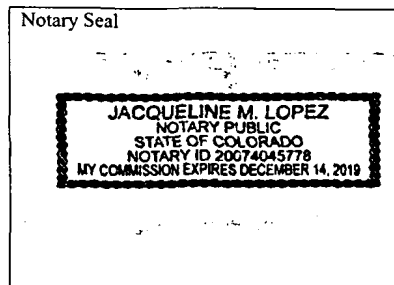

Jacqueline M. Lopez
(Signature of Notary Officer)
JACQUELINE M. LOPEZ
(Name of Notary Officer)
Notary Public for the State of: Colorado
Residing at: 9651 S. Quebec St.
My Commission Expires: 12/14/19

TENANT ACKNOWLEDGMENT

STATE OF COLORADO)
)ss.
COUNTY OF Arapahoe)

The foregoing instrument was acknowledged before me this 31 day of July 2017, by Becky John Haney, as Area Manager of AT&T Mobility Corporation.

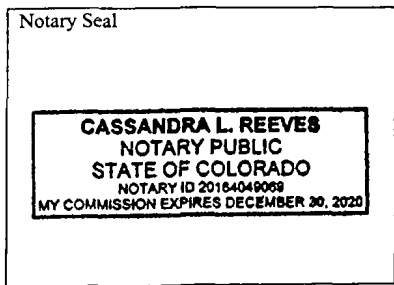

Cassandra L. Reeves
(Signature of Notary Officer)
Cassandra L. Reeves
(Name of Notary Officer)
Notary Public for the State of: Colorado
Residing at: Denver
My Commission Expires: 12/30/2020

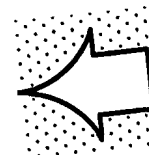

APPROVAL CERTIFICATE

THE BOARD OF COUNTY COMMISSIONERS HAS REVIEWED THE PROJECT AND HAS GRANTED APPROVAL FOR THE PROJECT TO PROCEED TO THE NEXT PHASE OF THE PROJECT.

PROJECT NAME: _____

PROJECT LOCATION: _____

PROJECT OWNER: _____

PROJECT ENGINEER: _____

PROJECT DATE: _____

PROJECT STATUS: _____

PROJECT DESCRIPTION: _____

PROJECT PURPOSE: _____

PROJECT BENEFITS: _____

PROJECT RISKS: _____

PROJECT COSTS: _____

PROJECT REVENUE: _____

PROJECT IMPACTS: _____

PROJECT COMPLIANCE: _____

PROJECT APPROVAL: _____

PROJECT SIGNATURE: _____

PROJECT DATE: _____

17305 EAST LINCOLN AVENUE AND THE WEST SIDE OF THE 17305 EAST LINCOLN AVENUE PROJECT
 IN THE TOWNSHIP AND RANGE OF THE 17TH TOWNSHIP AND RANGE
 COUNTY OF DOUGLAS, STATE OF COLORADO
 TOTAL AREA = 1.62 ACRES, LEASE PERMITS = 400 SQUARE FEET
 SITE NUMBER/DTI PLAN = SP2016-027 DENVER, CO, SP 2016-015



NOTES

THE PROJECT HAS BEEN REVIEWED AND APPROVED BY THE BOARD OF COUNTY COMMISSIONERS. THE PROJECT IS SUBJECT TO THE FOLLOWING CONDITIONS:

1. THE PROJECT SHALL BE COMPLETED BY THE DATE SPECIFIED IN THE PROJECT DESCRIPTION.
2. THE PROJECT SHALL BE COMPLETED IN ACCORDANCE WITH THE PROJECT DESCRIPTION AND THE PROJECT PURPOSE.
3. THE PROJECT SHALL BE COMPLETED IN ACCORDANCE WITH THE PROJECT BENEFITS AND THE PROJECT RISKS.
4. THE PROJECT SHALL BE COMPLETED IN ACCORDANCE WITH THE PROJECT COSTS AND THE PROJECT REVENUE.
5. THE PROJECT SHALL BE COMPLETED IN ACCORDANCE WITH THE PROJECT IMPACTS AND THE PROJECT COMPLIANCE.

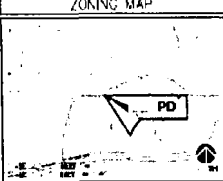
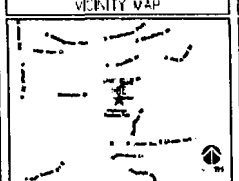

PROJECT DESCRIPTION

The project consists of the construction and installation of a communications facility at the intersection of 17305 East Lincoln Avenue and the West Side of the 17305 East Lincoln Avenue Project. The project includes the construction of a building, the installation of equipment, and the construction of a parking lot.

PROJECT PURPOSE

The purpose of the project is to provide a communications facility for the project owner.

PROJECT BENEFITS

The benefits of the project include the provision of a communications facility for the project owner, the creation of jobs, and the improvement of the local economy.

PROJECT RISKS

The risks of the project include the possibility of delays, the possibility of cost overruns, and the possibility of environmental impacts.

PROJECT COSTS

The costs of the project include the construction of the building, the installation of equipment, and the construction of the parking lot.

PROJECT REVENUE

The revenue of the project includes the rental of the communications facility to the project owner.

PROJECT IMPACTS

The impacts of the project include the construction of the building, the installation of equipment, and the construction of the parking lot.

PROJECT COMPLIANCE

The project complies with all applicable laws, regulations, and standards.

DRIVING DIRECTIONS

From Denver, CO:

1. Take I-70 East to Exit 173 (Lincoln Avenue).
2. Turn right onto Lincoln Avenue and travel East for approximately 1.6 miles.
3. Turn left onto the West Side of the 17305 East Lincoln Avenue Project.
4. The project is located on the right side of the road.

PROJECT SUMMARY

PROJECT NAME: _____

PROJECT LOCATION: _____

PROJECT OWNER: _____

PROJECT ENGINEER: _____

PROJECT DATE: _____

PROJECT STATUS: _____

PROJECT DESCRIPTION: _____

PROJECT PURPOSE: _____

PROJECT BENEFITS: _____

PROJECT RISKS: _____

PROJECT COSTS: _____

PROJECT REVENUE: _____

PROJECT IMPACTS: _____

PROJECT COMPLIANCE: _____

PROJECT APPROVAL: _____

PROJECT SIGNATURE: _____

PROJECT DATE: _____

at&t

INFINIGY8
 FROM 1680 TO 1690 MHz
 1680-1690 MHz
 1690-1700 MHz

smartlink

LINCOLN & JORDAN

CCF01431

10099211

17305 EAST LINCOLN AVE
GARDNER, CO 80134

717.8.5887

1 OF 6

Exhibit B-3

17305 E LINCOLN AVENUE, 2ND FLOOR
 A PORTION OF THE SW 1/4 SECTION 3, AND THE NW 1/4 SECTION
 16, TOWNSHIP 65S, RANGE 61W OF THE 6TH PRINCIPAL MERIDIAN
 COUNTY OF DOKLAS, STATE OF COLORADO
 TOTAL AREA - 14.87 ACRES LEASE AREA - 830 SQUARE FEET
 SITE IMPROVEMENT PLAN - 17305-007 (REVISED TO SP 2013-015)



Provided by
INFINIGY
 FROM ZERO TO INFINITY
 the solutions and services
 that make it all work
 1400 West 127th Street, Suite 100
 Greenwood, CO 80045
 Phone: 303.750.1170
 Fax: 303.750.1000
 www.infinigy.com

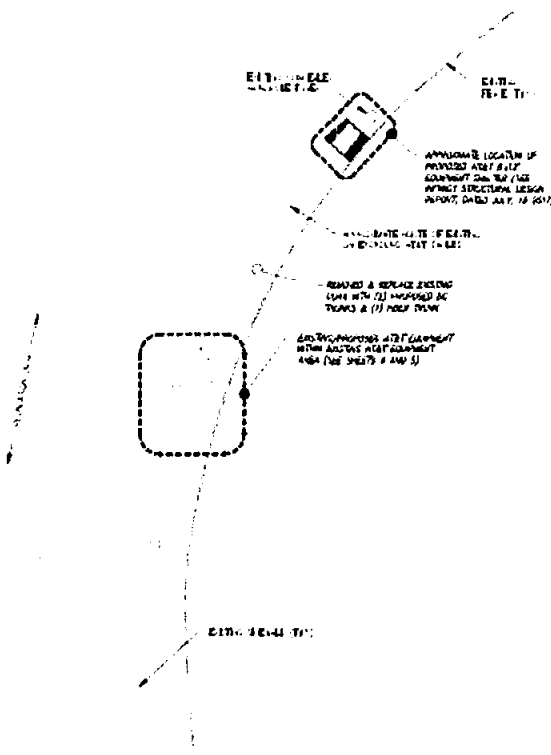

APPROVAL CERTIFICATE

DESIGNED BY:	INFINIGY
DESIGNED DATE:	INFINIGY
DESIGNED BY:	INFINIGY
DESIGNED DATE:	INFINIGY

FORM 1000 (REVISED 01/01/13) AND ALL THE RULES GOVERNING IT ARE PART OF THIS APPLICATION. CHECK THESE RULES IN THE STATE AND FEDERAL STATUTES AND REGULATIONS GOVERNING THE LICENSED USE OF AIR.

FILE NO.	FILE DATE	FILE TIME

LINCOLN & JORDAN

STATE LICENSE NO. **COE.01431**

FILE NO. **10099211**

**17305 EAST LINCOLN AVE
 GARDNER, CO 80134**

OVERALL SITE PLAN

SCALE AS SHOWN

2 OF 6

17305 E LINCOLN AVENUE, 2ND FLOOR
 A PORTION OF THE SW 1/4 SECTION 3, AND THE NW 1/4 SECTION
 16, TOWNSHIP 65S, RANGE 61W OF THE 6TH PRINCIPAL MERIDIAN
 COUNTY OF DOKLAS, STATE OF COLORADO
 TOTAL AREA - 14.87 ACRES LEASE AREA - 830 SQUARE FEET
 SITE IMPROVEMENT PLAN - 17305-007 (REVISED TO SP 2013-015)

OVERALL SITE PLAN



SCALE AS SHOWN

SCALE AS SHOWN

CODED DRAWING NOTES:

- EXIST. UNUSABLE UTILITIES
- EXIST. UTILITY
- NEW WATER AND SEWER
- NEW GAS
- NEW FIBER
- NEW ELECTRICAL
- NEW CONCRETE
- NEW ASPHALT
- NEW SIGN
- NEW LIGHTING
- NEW LANDSCAPE
- NEW FENCE
- NEW DRIVE
- NEW WALKWAY
- NEW BIKEWAY
- NEW TRAIL
- NEW BIKEWAY
- NEW TRAIL

11200 E LINCOLN AVENUE AND NEIGHBORHOOD
 A PORTION OF THE SW 1/4 SECTION 2, AND THE NW 1/4 SECTION 1A,
 TOWNSHIP 65S, RANGE 69W OF THE 6TH PRINCIPAL MERIDIAN,
 COUNTY OF COCKEAS, STATE OF COLORADO
 TOTAL AREA - 14.87 ACRES, LEASE AREA - 450 SQUARE FEET
 SITE IMPROVEMENT PLAN - SP2101-207 (REVISION TO SP 2013-015)

PLAN PROVIDED BY



INFINIGY®
 FROM FIBER TO MOBILE
 1605 North State Ave., Suite 200
 Denver, CO 80202
 303.733.1100
 For more info visit www.infinigy.com

PLAN PROVIDED BY

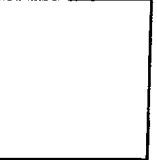
WORKSHEET NO. 1

THIS DRAWING IS A PRELIMINARY DESIGN AND THE WORK SHOWN IS FOR INFORMATION ONLY. THE CONTRACTOR SHALL BE RESPONSIBLE FOR OBTAINING ALL NECESSARY PERMITS AND APPROVALS FROM THE APPROPRIATE AGENCIES.

NO.	DESCRIPTION	DATE
1	ISSUED FOR PERMIT	08/15/13
2	REVISED PER PERMITTING AGENCY COMMENTS	08/22/13
3	REVISED PER PERMITTING AGENCY COMMENTS	09/10/13
4	REVISED PER PERMITTING AGENCY COMMENTS	09/10/13
5	REVISED PER PERMITTING AGENCY COMMENTS	09/10/13
6	REVISED PER PERMITTING AGENCY COMMENTS	09/10/13

LINCOLN & JORDAN

COE.01431

10099211

**17305 EAST LINCOLN AVE
DARKEN, CO 80134**

ENLARGED SITE PLAN #2

4 OF 6

ASPHALT & CONCRETE SHALL BE CONCRETE WITH 10% PORTLAND CEMENT FIBER FIBRE IN PLACE. ALL CONCRETE SHALL BE 4000 PSI WITH 10% PORTLAND CEMENT FIBER FIBRE IN PLACE. ALL CONCRETE SHALL BE 4000 PSI WITH 10% PORTLAND CEMENT FIBER FIBRE IN PLACE. ALL CONCRETE SHALL BE 4000 PSI WITH 10% PORTLAND CEMENT FIBER FIBRE IN PLACE.

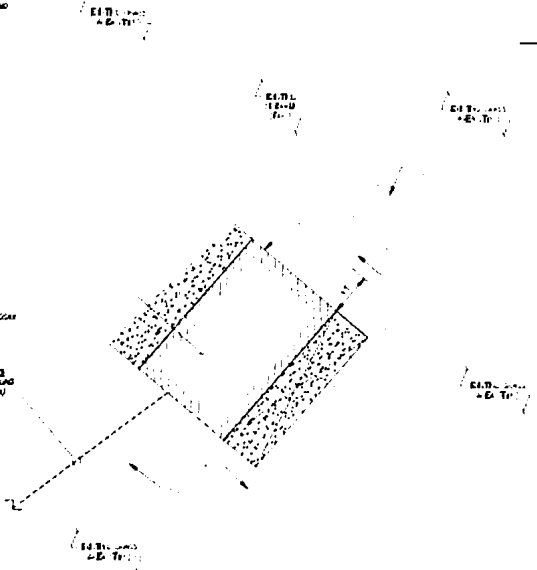

APPROVAL / IDENTIFICATE

DESIGNED BY	DATE
DRAWN BY	DATE
CHECKED BY	DATE
APPROVED BY	DATE

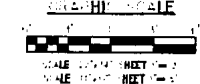

NOTES:
 1. ALL CONCRETE SHALL BE 4000 PSI WITH 10% PORTLAND CEMENT FIBER FIBRE IN PLACE.
 2. ALL CONCRETE SHALL BE 4000 PSI WITH 10% PORTLAND CEMENT FIBER FIBRE IN PLACE.
 3. ALL CONCRETE SHALL BE 4000 PSI WITH 10% PORTLAND CEMENT FIBER FIBRE IN PLACE.

ENLARGED SITE PLAN #2

17305 E LINCOLN AVENUE AND NEIGHBORING
 A PORTION OF THE SW 1/4 SECTION 8, AND THE NW 1/4 SECTION
 18, TOWNSHIP 65, RANGE 66W OF THE 6TH PRINCIPAL MERIDIAN
 COUNTY OF DOUGLAS, STATE OF COLORADO
 TOTAL AREA = 14.87 ACRES LEASE AREA = 0.30 SQUARE FEET
 SITE IMPROVEMENT PLAN - 05/24/14-027 (REVISION TO SP 272-015)

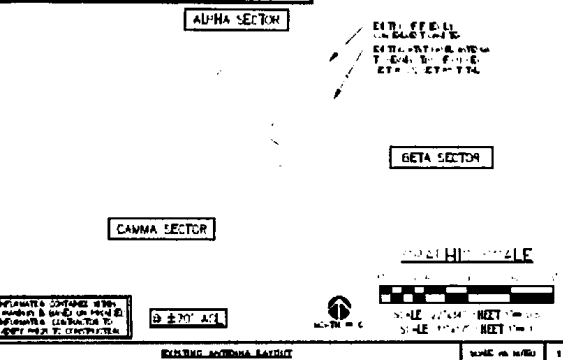

THE COPIES OF THIS PLAN & SPECIFICATIONS ARE TO BE KEPT AT THE SITE FOR THE DURATION OF THE LEASE. THE ORIGINAL PLAN & SPECIFICATIONS ARE TO BE KEPT AT THE SITE FOR THE DURATION OF THE LEASE.

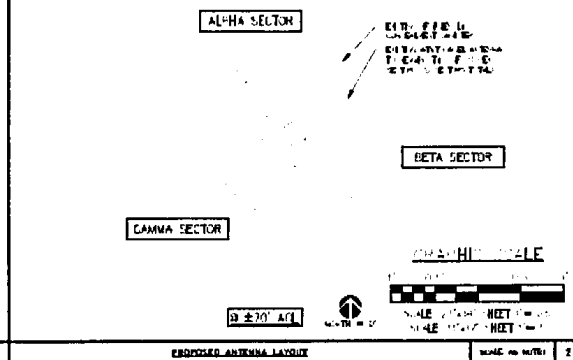

EXISTING ANTENNA LAYOUT SHEET NO. 00101 1

PROPOSED ANTENNA LAYOUT SHEET NO. 00101 2

THE COPIES OF THIS PLAN & SPECIFICATIONS ARE TO BE KEPT AT THE SITE FOR THE DURATION OF THE LEASE. THE ORIGINAL PLAN & SPECIFICATIONS ARE TO BE KEPT AT THE SITE FOR THE DURATION OF THE LEASE.

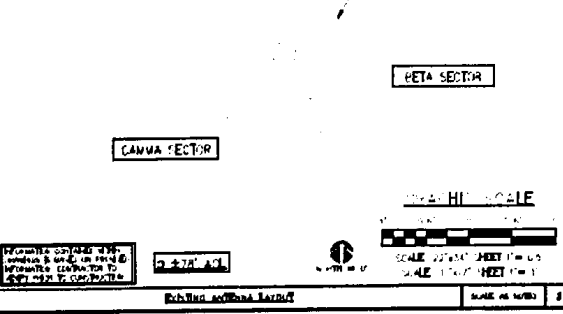

THE COPIES OF THIS PLAN & SPECIFICATIONS ARE TO BE KEPT AT THE SITE FOR THE DURATION OF THE LEASE. THE ORIGINAL PLAN & SPECIFICATIONS ARE TO BE KEPT AT THE SITE FOR THE DURATION OF THE LEASE.

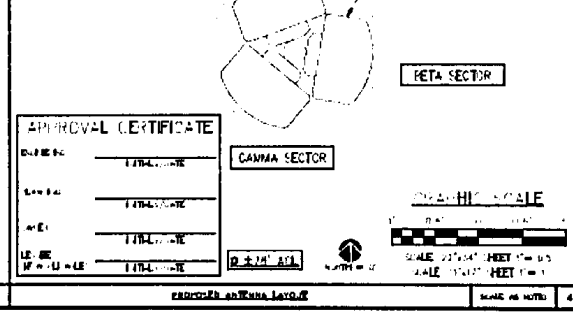

THE COPIES OF THIS PLAN & SPECIFICATIONS ARE TO BE KEPT AT THE SITE FOR THE DURATION OF THE LEASE. THE ORIGINAL PLAN & SPECIFICATIONS ARE TO BE KEPT AT THE SITE FOR THE DURATION OF THE LEASE.

DATE	BY	REVISION

LINCOLN & JORDAN

CC# 01431

10099211

17305 EAST LINCOLN AVE
 GARDNER, CO 80134

ANTENNA LAYOUTS

6 OF 6

APPROVAL CERTIFICATE

DATE: _____

BY: _____

FOR: _____

SCALE: 1" = 270' AS SHOWN

GENERAL DESIGN NOTES

- A. **STANDARDS AND DESIGN CODES:**
 - INDUSTRY STANDARD: 2015 INTERNATIONAL BUILDING CODES
 - STEEL MANUAL: AISC-LRFD 14TH EDITION
 - CONCRETE CODE: AC 308-14
 - WELDING CODE: AWS D11.1 LATEST EDITION
- B. **DESIGN LOADS:**
 - 1. SNOW: GROUND SNOW LOAD 20PSF
 - 2. LIVE: ROOF LIVE LOAD 20PSF
FLOOR LIVE LOAD 40PSF
 - 3. WIND: 15 MPH BASIC WIND SPEED (ULTIMATE)
EXP. COEFF. C
RISK CATEGORY IV
IMPORTANCE FACTOR MICROSEISMIC
MAPPED SPECTRAL RESPONSE ACCELERATIONS
S₁=0.14, S₂=0.57

CONCRETE MASONRY NOTES

1. CONCRETE MASONRY MATERIALS AND CONSTRUCTION SHALL CONFORM TO THE AMERICAN CONCRETE INSTITUTE (ACI) 530
2. CONCRETE MASONRY UNITS SHALL CONFORM TO ASTM C 90 AND SHALL BE MADE WITH LIGHTWEIGHT AGGREGATE. MINIMUM NET AREA COMPRESSIVE STRENGTH OF MASONRY UNITS SHALL BE 1,500 PSI AT 28 DAYS.
3. COMPRESSIVE STRENGTH OF MASONRY SHALL BE DETERMINED BY THE UNIT STRENGTH METHOD AS SET FORTH IN ACI 530.1. THE NET AREA COMPRESSIVE STRENGTH OF MASONRY, F_m, SHALL BE 1,500 PSI AT 28 DAYS.
4. MORTAR SHALL BE TYPE M OR S AND SHALL COMPLY WITH ASTM C270, PROPERTIES OR PROPERTIES SPECIFICATION.
5. GROUT SHALL COMPLY WITH ASTM C 476, PROPERTIES SPECIFICATION, OR SHALL BE PROPORTIONED TO OBTAIN A DOCUMENTED 28 DAY COMPRESSIVE STRENGTH OF 2,000 PSI.
6. REINFORCING STEEL SHALL COMPLY WITH ASTM A 615, GRADE 60, CHOP FABRICATE REINFORCING BARS WHICH ARE SHOWN TO BE BENT OR HOOKED.
7. ALL BOND BEAMS, REINFORCED CELLS AND CELLS WITH EXPANSION BOLTS, EMBED PLATES OR OTHER ANCHORS AND ALL CELLS BELOW GRADE SHALL BE GROUTED COLD GROUT. PROCEDURE SHALL COMPLY WITH ACI 530.1.
8. PROVIDE REINFORCING BARS OF THE GIVEN SIZE AND SPACING SHOWN. LAP CONTIGUOUS REINFORCING STEEL 48 BAR DIAMETERS UNLESS OTHERWISE NOTED. PROVIDE MECHANICAL COUPLERS FOR ALL BARS AT CONTRACTOR'S OPTION.
9. PROVIDE REINFORCING STEEL BOWELS OF THE SAME SIZE AND SPACING AS VERTICAL REINFORCING FROM THE SUPPORTING STRUCTURE. BOWELS SHALL HAVE STANDARD 90° HOOKS. LAP LENGTH FOR BOWELS FROM FOUNDATION NOT OTHERWISE NOTED MAY BE 36 X BAR DIAMETER.
10. PROVIDE STANDARD 4 GAGE LADDER TYPE HORIZONTAL JOINT REINFORCING IN CMU WALLS AT 16 INCHES ON CENTER AND IN TWO JOINTS IMMEDIATELY ABOVE AND BELOW ALL OPENINGS, EXTENDING A MINIMUM OF 2 FEET BEYOND THE JAMB ON EACH SIDE OF THE OPENING, EXCEPT AT CONTROL JOINTS.

FOUNDATION NOTES

1. ALL WORKMANSHIP AND MATERIALS SHALL BE IN ACCORDANCE WITH THE LATEST EDITION OF ACI 301 AND ACI 309.
2. CONCRETE MINIMUM STRENGTH IN 28 DAYS TO BE 3,000 PSI.
3. BAR REINFORCING ASTM A615, GRADE 60.
4. UNLESS OTHERWISE SHOWN, ALL REINFORCING SHALL BE DETAILED IN ACCORDANCE WITH ACI 310 LATEST EDITION.
5. UNLESS OTHERWISE NOTED, REINFORCING SHALL HAVE THE FOLLOWING MINIMUM CONCRETE COVERS: 3" COVER WHERE LIFEREMED AND AGAINST EARTH, 2" WHERE FORMED AND NOT AGAINST EARTH, SEE ACI CODE.
6. PROVIDE 3/4" CHAMFER AT ALL EXPOSED CONCRETE CORNERS AND EDGES.
7. SPECIAL ATTENTION SHALL BE GIVEN TO CONCRETE PLACED DURING HOT OR COLD WEATHER. ALL SPECIAL PRACTICES PRECEDED BY ACI SHALL BE FOLLOWING DURING THE PLACEMENT OF CONCRETE DURING SPECIAL WEATHER CONDITIONS.
8. FOUNDATION DESIGN BASED ON PRELIMINARY SOIL PARAMETERS, AND ALLOWABLE SOIL BEARING PRESSURE OF 1,000 PSF.
9. ALL REINFORCING, ANCHOR BOLTS, EMBEDDED STEEL, ANCHORS AND ALL OTHER EMBEDDED ITEMS SHALL BE IN PLACE BEFORE START OF CONCRETE PLACEMENT.
10. REMOVE ALL LODGE MATERIAL AND DEBRIS FROM COMPACTED SUBGRADE SURFACE PRIOR TO PLACING CONCRETE. THE TOP OF ALL FOUNDATIONS SHALL BE SQUARE AND LEVEL WITH A SMOOTH FLOAT FINISH. ALL DIMENSIONS SHALL BE WITHIN ± 1/8" INCH.

WOOD FRAMING NOTES

1. DOUGLAS FIR LARCH NO.1 GRADE IDENTIFIED BY THE GRADING OR INSPECTION AGENCY THAT HAS BEEN APPROVED BY AN ACCREDITATION BODY THAT COMPLES WITH CCC PS 20, GRADING PRACTICES AND IDENTIFICATION SHALL COMPLY WITH RULES PUBLISHED BY AN AGENCY APPROVED IN ACCORDANCE WITH THE PROCEDURES OF CCC PS 20.
2. BOLT HOLES SHALL BE 1/16" MAXIMUM LARGER THAN THE BOLT SIZE. RE-TIGHTEN ALL NUTS PRIOR TO CLOSING IN.
3. ALL SILL OR PLATES RESTING ON CONCRETE OR MASONRY SHALL BE PRESURE TREATED DOUGLASS FIR. BOLTS SHALL BE PLACED 4 INCHES FROM THE END OF A PLATE, OR FROM A NOTCH GREATER THAN 1/2 THE WIDTH OF THE PLATE, AND SPACED AT INTERVALS NOTED. DO NOT NOTCH JOISTS, RAFTERS OR BEAMS EXCEPT WHERE SHOWN IN DETAILS. OBTAIN ENGINEER'S APPROVAL FOR ANY HOLES OR NOTCHES NOT DETAILED.
4. ALL WALLS, BOLTS, HOLD-DOWNS, STRAPS OR OTHER STEEL FASTENERS IN CONTACT WITH PRESURE TREATED TIMBER SHALL BE HOT-DIPPED GALVANIZED, STAINLESS STEEL OR OTHERWISE TREATED OR ISOLATED TO PREVENT CHEMICAL ATTACK. CONTRACTOR SHALL VERIFY TREATMENT METHOD AND CONFIRM APPROPRIATE CORROSION RESISTANCE BE PROVIDED IN ACCORDANCE WITH HARDWARE SUPPLIER RECOMMENDATIONS.
5. SPECIFICATIONS:
 - A. WOOD CONSTRUCTION, UNLESS OTHERWISE NOTED, SHALL CONFORM TO THE "GENERAL CONSTRUCTION REQUIREMENTS", SECTION 2304 OF THE INTERNATIONAL BUILDING CODE AND THE NATIONAL DESIGN SPECIFICATION FOR WOOD CONSTRUCTION. B. SHEATHING UNLESS OTHERWISE NOTED SHALL CONFORM TO U.S. PRODUCT STANDARD PS-1 FOR CONSTRUCTION AND INDUSTRIAL PLYWOOD AND APA DESIGN/CONSTRUCTION GUIDE - RESIDENTIAL AND COMMERCIAL. EACH PANEL SHALL BE IDENTIFIED WITH AN APA GRADE TRADEMARK.

at&t

INFINIGY
FROM ZERO TO INFINITELY

smartlink

JEFFREY V. JORDAN
PROFESSIONAL ENGINEER
43122

REVISION	DATE	BY

LINCOLN & JORDAN

COE.01431

10099211

17005 EAST LINCOLN AVE
GARDNER, CO 80134

GENERAL NOTES

2001



INFINIGY

PROFESSIONAL ENGINEER
 LICENSE NO. 43122
 STATE OF COLORADO



LINCOLN & JORDAN
 STRUCTURAL ENGINEERS

DATE	BY	REVISION

PROJECT NO. **COL01431**

10099211

17305 EAST LINCOLN AVE
 GARDNER, CO 80134

GREGORY A. JORDAN
 STRUCTURAL ENGINEERING

5002

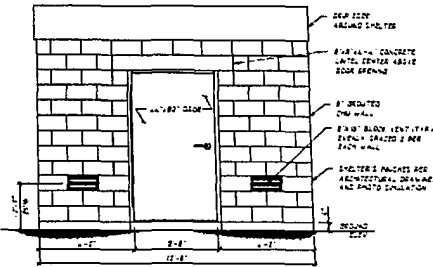

NORTH ELEVATION
 W-2

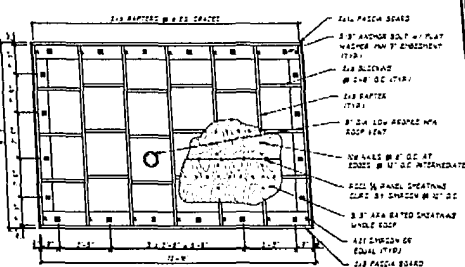

ROOF PLAN
 W-2

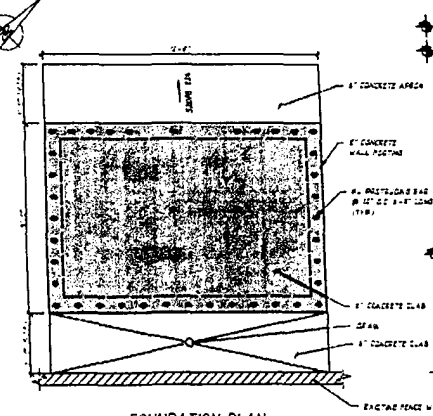

FOUNDATION PLAN
 W-2

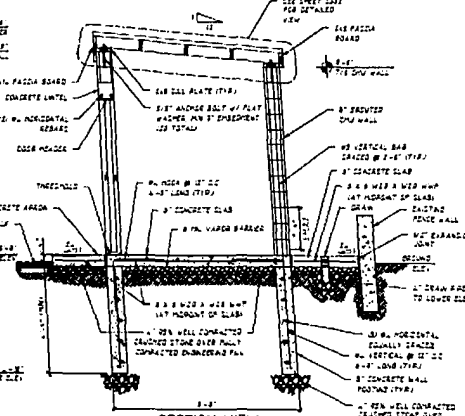

SECTION VIEW
 W-2

Market: Rocky Mountain Region
Cell Cite Number: COU1431
Cell Site Name: Lincoln & Jordan
Fixed Asset Number: 10099211

FOURTH AMENDMENT TO COMMUNICATIONS SITE LEASE AGREEMENT

THIS FOURTH AMENDMENT TO COMMUNICATIONS SITE LEASE AGREEMENT (“Fourth Amendment”), dated as of the latter of the signature dates below (“Effective Date”), is by and between the **BOARD OF COUNTY COMMISSIONERS OF THE COUNTY OF DOUGLAS, STATE OF COLORADO** (“Landlord”) and **NEW CINGULAR WIRELESS PCS, LLC**, a Delaware limited liability company (“Tenant”). The Landlord and the Tenant are hereinafter collectively referred to as the “Parties” and individually to as a “Party.”

RECITALS

WHEREAS, the Parties entered into a Communications Site Lease Agreement dated February 21, 2006, whereby Landlord leased to Tenant certain Premises, therein described, that are a portion of the property located at 17305 East Lincoln Avenue, Park, Colorado 80134 (“Original Agreement”); and

WHEREAS, the Parties entered into a First Amendment to Communications Site Lease Agreement dated April 24, 2012 (“First Amendment”), whereby the Parties amended the Agreement to (i) increase the leased space; (ii) allow Tenant to replace the existing light pole tower; (iii) grant Tenant an additional five-foot wide utility right-of-way; and (iv) increase monthly rent; and

WHEREAS, the Parties entered into a Second Amendment to Communications Site Lease Agreement dated November 4, 2014 (“Second Amendment”), whereby the Parties amended the Agreement to increase the leased space; and

WHEREAS, the Parties entered into a Third Amendment to Communications Site Lease Agreement dated July 31, 2017 (“Third Amendment”), whereby the Parties amended the Agreement to (i) increase the leased space; and (ii) permit Tenant to add, modify, and/or replace equipment to comply with any current or future federal, state, and local law including but not limited to emergency 911 communication services; and

WHEREAS, the Original Agreement, First Amendment, Second Amendment, Third Amendment, and this Fourth Amendment are collectively referred to herein as the “Agreement”; and

WHEREAS, the Parties now desire to further amend the Agreement a fourth time to (i) adjust monthly rent; (ii) amend the Term; and (iii) set forth method of payment standards in Exhibit C, attached hereto and incorporated here; and

WHEREAS, the Parties now have determined that additional clarifications are needed.

NOW THEREFORE, the Parties agree as follows:

1. **Rent Adjustment.** Commencing on January 1, 2026, monthly rent shall be in the amount of **THREE THOUSAND THREE HUNDRED DOLLARS AND ZERO CENTS (\$3,300.00)** with an annual four percent (4%) increase on each January 1st of each subsequent year of the Term thereafter. In no event shall the Landlord be liable for payment under this Fourth Amendment for any amount in excess thereof. The Landlord is not under obligation to make any future apportionment or allocation to this Fourth Amendment, nor is anything set forth herein a limitation of liability for the Tenant. Any potential expenditure for this Fourth Amendment outside the current fiscal year is subject to future annual appropriation of funds for any such proposed expenditure.
2. **Term.** The Parties mutually agree that the Term of this Fourth Amendment shall commence as of 12:01 a.m. on **January 1, 2026**, and shall continue for five years terminating at 12:00 a.m. on **December 31, 2030**. This Agreement shall automatically be renewed at the end of the First Renewal Term (each a “Subsequent Renewal Term”) for four five-year successive terms unless (i) the Tenant notifies the Landlord of its intention not to renew the Agreement prior to commencement of the next Subsequent Renewal Term; or (ii) the Landlord exercises its right to terminate this Agreement in accordance with and pursuant to Paragraph 10 Termination of the Original Agreement. As used herein, the First Renewal Term and any Subsequent Renewal Term shall also mean a “Term” of the Agreement. This Fourth Agreement and/or any extension of its original Term shall be contingent upon annual funding being appropriated, budgeted, and otherwise made available for such purposes and subject to the Landlord’s satisfaction with all products and services received during the preceding Term.
3. **Notices.** Notices concerning termination of the Agreement, notices of alleged or actual violations of the terms or provisions of the Agreement, and all other notices shall be made as follows:

by the Tenant to the Landlord:

Dept of Community Development
ATTN: Terence Quinn
100 Third St. Castle Rock, CO 80104
Ph: (303) 660-7460
Email: parksandtrails@douglas.co.us

with a copy to:

Douglas County Attorney’s Office
100 Third Street
Castle Rock, CO 80104

Ph: (303) 660-7414
Email: attorney@douglas.co.us

and by the Landlord to the Tenant:

New Cingular Wireless PCS, LLC
Attn: Legal Dept. – Network Operations
Re: Cell Site #COL01431,
Cell Site Name: Lincoln & Jordan (CO)
Dallas, TX 75202-4206
Email: NoticeIntake@att.com

Said notices shall be delivered personally during normal business hours to the appropriate office above, or by prepaid first-class U.S. mail, via facsimile, or other method authorized in writing by the Authorized Representative. Mailed notices shall be deemed effective upon receipt or three (3) days after the date of mailing, whichever is earlier. The Parties may from time-to-time designate substitute addresses or persons where and to whom such notices are to be mailed or delivered, but such substitutions shall not be effective until actual receipt of written notification.

4. **Other Terms and Conditions Remain.** In the event of any inconsistencies between the Agreement, First Amendment, Second Amendment, Third Amendment, and this Fourth Amendment, the terms of this Fourth Amendment shall control. Except as expressly set forth in this Fourth Amendment, the Agreement otherwise is unmodified and remains in full force and effect. Each reference in the Agreement to itself shall be deemed also to refer to this Fourth Amendment.
5. **Capitalized Terms.** All capitalized terms used but not defined herein shall have the same meanings as defined in the Agreement.

(Remainder of Page Intentionally Blank)

IN WITNESS WHEREOF, the Parties have executed this Fourth Amendment as of the last date written below.

New Cingular Wireless PCS, LLC
A Delaware limited liability company

BY:

Signed by:

03357F7315E0426...

Printed Name Ashwani Goel

Title: Director of Engineering

DATE: 2/25/2025

**BOARD OF COUNTY COMMISSIONERS
OF THE COUNTY OF DOUGLAS**

BY: _____

DATE: _____

APPROVED AS TO FISCAL CONTENT:

APPROVED AS TO LEGAL FORM:

Andrew Copland
Director of Finance

Arielle J. Denis
Assistant County Attorney

DATE: _____

DATE: _____

APPROVED AS TO INSURANCE REQUIREMENTS:

Megan Datwyler
Risk Manger

EXHIBIT C
PAYMENT TERMS

The Tenant shall pay to the Landlord the full 12 months of rent on or before the final business day of January each calendar year of the current Term.

Rent shall be payable by the Tenant to the Landlord via ACH Direct Deposit or check.

- Payments by ACH Direct Deposit: The Tenant shall notify the Landlord via email to parksandtrail@douglas.co.us that the payment has been made.
- Payments by check: The Tenant shall deliver payments to:
Parks, Trails, and Building Grounds
Attn: Steve Shoultz, Assistant Director of Parks, Trails, and Building Grounds
9651 South Quebec St.
Littleton, CO 80130